

NUMATICS®

A Series

Aluminum NFPA Interchangeable Cylinder Line



www.numatics.com

A Series

Features and Benefits	3
Standard Mounts	4
How to Order	5
Basic No Mount Cylinder Dimensions	6
Rod End Dimensions	7
Flange Mount Dimensions	8
Clevis Mount Dimensions	9
Eye Mount Dimensions	10
Angle Mount Dimensions	11
Side Lug Mount Dimensions	12
Bottom Tap Mount Dimensions	13
Extended Tie Rod Mount Dimensions	14
Trunnion Mount Dimensions	15
Sleeve Nut Mount Dimensions	16
Double Rod End Dimensions	17
Tandem Cylinder Dimensions	18
Multi-Position Cylinder Dimensions	19
Back to Back Cylinder Dimensions	20
Air-Oil Tanks	21
Air-Oil Tank Dimensions	22-24
Stop Tube Data	25
Force Tables	26
Approximate Cylinder Weights	26
Metallic Rod Scraper	27
Electroless Nickel Protection	27
Adjustable Stroke Cylinder	27
Save Air Stroke Adjuster	27
Silencer Bumper Seal	28
Rod Boot	28
Accessories	29-30
A Series World Switches	31-32
How to Order - A Series Piston Rod Assembly	33
How to Order - A Series Repair Kit	37
How to Order - A Series Seal Kit	38
Piston Rod Assembly Kit Installation Instructions	39
Repair Kit and Seal Kit Removal/Installation Instructions	39
Diagrams	40
Seal Installation Guide	41

The **A Series** is an aluminum NFPA Interchangeable cylinder line that is designed and built to excel in the most demanding applications. The A Series encompasses many value-added features such as an extra long graphite filled cast iron rod bushing and a standard oversized wear band that is located on the rear of the piston. Additionally, the A Series includes the well-proven “T” piston seal configuration made from carboxilated nitrile with self-lubricating PTFE compound. These are just a sample of the features that make the A Series the superior NFPA Interchangeable air cylinder line.

Tube

The **tube** is hard coat anodized. The hard coating is an electro-chemical process, which produces a very dense surface of aluminum oxide. This surface has extreme hardness (60 Rc), excellent wear and corrosion resistance, and a low coefficient of friction.

End Caps

The **end caps** are accurately machined from (6061-T6) solid aluminum bar stock. They are anodized for corrosion resistance. Additionally, a recess on the piston-mating surface (at both ends) enables the air to work on a larger piston area for effortless breakaway.

Rod Bushing

The A Series includes a graphite filled, cast iron **rod bushing** that is extra long in length. Graphite filled offers the best bearing surface when using a hard chrome plated steel piston rod. Cast iron provides maximum resistance against wear. The added length adds superior alignment and support of the piston rod as well as provides maximum load bearing support.

Rod Seal

The carboxilated nitrile with PTFE compound **rod seal** is self-lubricating and durable. The rounded lip design ensures proper sealing and long life.

Rod Wiper

The standard **rod wiper** construction is a highly durable polyurethane.

Piston Rod

High strength steel (100,000 psi minimum yield) **piston rod** has a ground, polished, and chrome plated surface. This surface provides maximum life for both the rod bushing and the seals.

Bushing Retainer

The **bushing retainer** allows cartridge removal (cylinder repair) without complete disassembly.

Tie Rods

The **tie rods** are 100,000 psi minimum yield steel for maximum holding power. The threads are roll formed for superior strength and engagement.

Piston Seal

The **piston seal** is a carboxilated nitrile with PTFE compound making it self-lubricating. The “T” with back-up ring construction prevents rolling and seals at all pressures.

Wear Band

The **wear band** is a stable, lubricating strip located on the piston. We separated the load bearing points by locating the wear band at the rear of the piston. This maximizes column strength at full extension.

Piston

The solid aluminum alloy **piston** is strong and durable.



Cushion Seal

The floating **cushion seal** design enables rapid stroke reversal by providing instantaneous full flow to the piston. Each cushion has a flush, retained adjustment needle.

Tube End Seal

The **tube end seals** are compression type and reusable.

Ports

Our enhanced **port** design enables the cylinder to work more efficiently. Through the use of precise machining depths and tool shape, we are able to smooth the flow path into and out of the cylinder.

Standard Specifications:

- Meets NFPA specifications
- Bore sizes from 1-1/2" through 6"
- Piston rod diameters from 5/8" to 1-3/4"
- Maximum pressure rating is 250 psi air
- Standard temperature -10°F to 165°F (-23°C to 74°C)
- NPTF ports
- Flexible port and cushion location
- Multitude of mounting options

Standard A Series Mounts

Centerline Mounts

X0 Mount
Basic No Mount

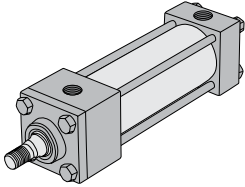

X1 Mount
Extended Tie Rods – Both Ends

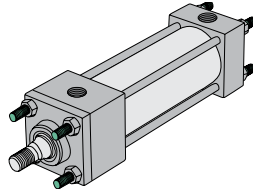

X2 Mount
Extended Tie Rods – Cap End

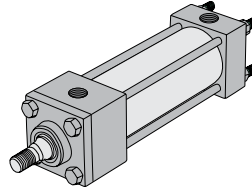

X3 Mount
Extended Tie Rods – Head End

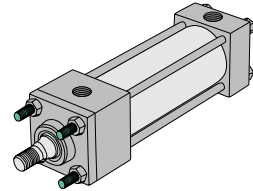

F1 Mount
Head Rectangular Flange

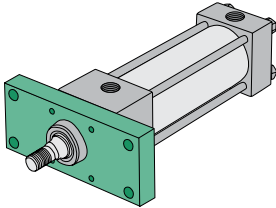

F2 Mount
Cap Rectangular Flange

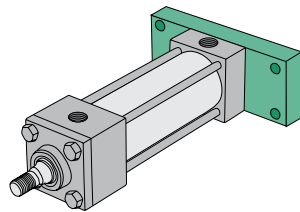

DA Mount
Double Rod End

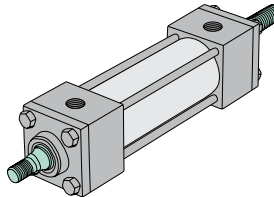

Pivot Mounts

P1 Mount
Fixed Clevis

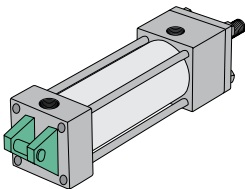

P2 Mount
Detachable Clevis

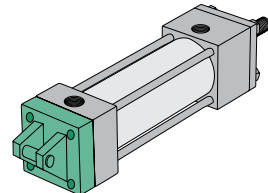

P3 Mount
Fixed Eye

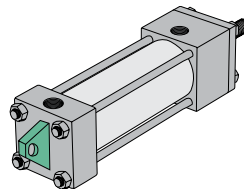

P4 Mount
Detachable Eye

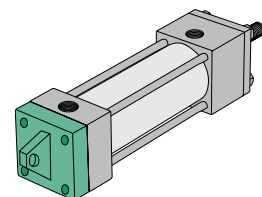

T1 Mount
Head Trunnion

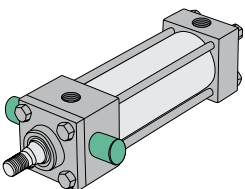

T2 Mount
Cap Trunnion

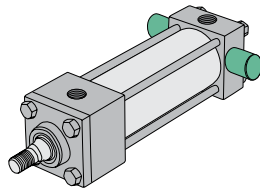

T4 Mount
Intermediate Trunnion

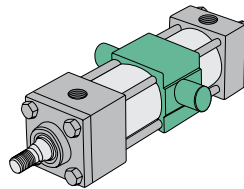

Foot Mounts

S1 Mount
Angle Mount

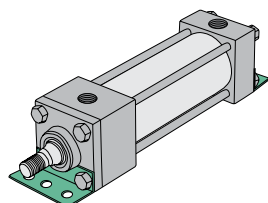

S2 Mount
Side Lugs

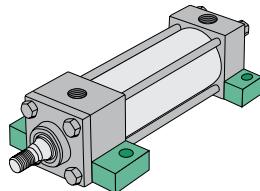

S4 Mount
Bottom Tapped

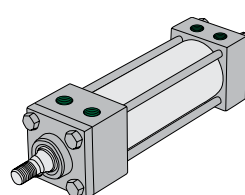

How to Order

Leave blank unless using MU or BK option.
P1 A L - 04 A 1 D - C AA 0 04 0

Mount

- F1 = Front Flange
 - F2 = Rear Flange
 - P1 = Fixed Clevis
 - P2 = Detachable Clevis
 - P3 = Fixed Eye
 - P4 = Detachable Eye
 - S1 = Angle Mount
 - S2 = Side Lug Mount
 - S4 = Bottom Tap
 - SE = Bottom Tap Sleeve Nut
 - SN = Sleeve Nut
 - T1 = Head Trunnion (Fixed Steel Ears)
 - T6 = Head Trunnion (Removable Aluminum Head)
 - T2 = Cap Trunnion (Fixed Steel Ears)
 - T7 = Cap Trunnion (Removable Aluminum Head)
 - T4* = Mid Trunnion
 - X0 = Basic No Mount
 - X1 = Extended Tie Rods Both Ends
 - X2 = Extended Tie Rod Cap
 - X3 = Extended Tie Rod Head
- *Specify "XI" length.

Type

- A = A Series
- NFPA Interchangeable

Bore

- K = 1-1/2" R = 4"
- L = 2" T = 5"
- M = 2-1/2" U = 6"
- P = 3-1/4"

Full Inches of Stroke

- 00 = 0" Stroke
- 01 = 1" Stroke
- 02 = 2" Stroke
- 03 = 3" Stroke
- 99 = 99" Stroke

Note: Consult factory for strokes greater than 99".

Fractional Inches of Stroke

- A = 0" I = 1/2"
- B = 1/16" J = 9/16"
- C = 1/8" K = 5/8"
- D = 3/16" L = 11/16"
- E = 1/4" M = 3/4"
- F = 5/16" N = 13/16"
- G = 3/8" O = 7/8"
- H = 7/16" P = 15/16"

Rod Code

- 1 = Style #1 Standard Rod Diameter
- 2 = Style #2 Standard Rod Diameter
- 3 = Style #3 Standard Rod Diameter
- 4 = Special Standard Rod Diameter (must specify threads)
- 5 = Special Oversize Rod Diameter (must specify threads)
- 6 = Style #1 Oversize Rod Diameter
- 7 = Style #2 Oversize Rod Diameter
- 8 = Style #3 Oversize Rod Diameter
- U = Male Coupling Rod End Standard Rod Diameter
- V = Male Coupling Rod End Oversized Rod Diameter

Cylinder Orientation

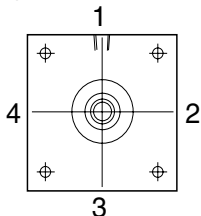

Ports are normally located in position 1.
 Cushions are normally located in position 2.

Rod End Styles, Diameters and Threads

Diameter	Style #1 Standard Male	Style #2 Optional Male	Style #3 Optional Female
0.625	7/16-20	1/2-20	7/16-20
1.000	3/4-16	7/8-14	3/4-16
1.375	1-14	1 1/4-12	1-14
1.750	1 1/4-12	1 1/2-12	1 1/4-12

Fractional Inches of Stroke

- A = 0" I = 1/2"
- B = 1/16" J = 9/16"
- C = 1/8" K = 5/8"
- D = 3/16" L = 11/16"
- E = 1/4" M = 3/4"
- F = 5/16" N = 13/16"
- G = 3/8" O = 7/8"
- H = 7/16" P = 15/16"

Full Inches of Stroke

- 00 = 0" Stroke
- 01 = 1" Stroke
- 02 = 2" Stroke
- 03 = 3" Stroke

Magnet

- 0 = No Magnet
- 2 = Reed Magnet

Options

- AA = No Options
 - BA** = Bumpers Both Ends
 - BC** = Bumper Cap Only
 - BH** = Bumper Head
 - BK = Back to Back Cylinder
 - CT = Composite Tube
 - DA = Double Rod End
 - EB = Silencer Bumpers
 - GA = High Temperature Rod Boot
 - KA* = Stroke Adjuster
 - LB = Low Breakaway Seals
 - LP = Profile Tubing (1-1/2" to 3-1/4" Bores)
 - MA = Metallic Rod Scraper
 - MU = Multiposition Cylinder
 - NA = Nickel Plated Cylinder, Stainless Steel Rod and Tie Rods
 - PA = Polypak Rod Seal
 - RB = Rod Boot
 - RA* = Save Air Stroke Adjuster
 - SA = Stainless Steel Piston Rod
 - SS = Stainless Piston Rod and Tie Rod
 - ST = Stainless Tie Rods
 - TD = Tandem Cylinder
 - VA = FKM Seals
 - YA = NuLock Rod Brake
 - YE = NuLock Rod Brake Ready
 - 1A* = Rod Extension
 - 2A* = Thread Extension
 - 12* = Rod and Thread Extension
 - 3A = Studded Rod End
 - 4A* = Stop Tube
 - 4D* = Double Piston Stop Tube
- * Specify length.
 **Bumpers add .062" to OAL (per bumper).
 Consult factory for information regarding combination options and options not listed.

Cushions

Position	1	2	3	4	Fixed
No Cushion	A	A	A	A	A
Head and Cap	B	C	D	E	Y
Head Only	F	G	H	J	W
Cap Only	K	L	M	N	V

Ports

Position	1/8"	1/4"	3/8"	1/2"	3/4"
1	B	C	D	E	F
2	H	I	J	L	K
3	N	O	P	Q	R
4	T	U	V	W	X

Z = Special Ports (must specify ports/size(s) and location(s))

Consult factory for additional details

Rod Diameters by Bore Size

Bore	Standard Dia.	Oversized Dia.
1-1/2"	0.625	1.000
2"	0.625	1.000
2-1/2"	0.625	1.000
3-1/4"	1.000	1.375
4"	1.000	1.375
5"	1.000	1.375
6"	1.375	1.750

The above information is for information purposes only and not all combinations are available.

Dimensions: Inches

Basic No Mount Cylinder

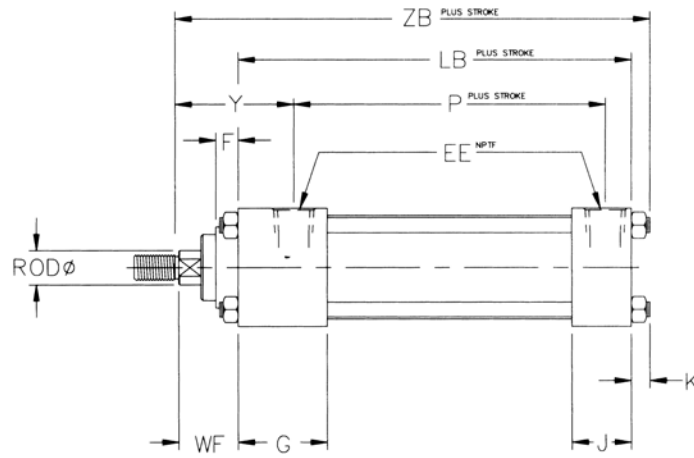

Mount Code X0

NFPA MX0

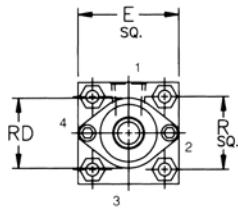

1-1/2" Through 2-1/2"

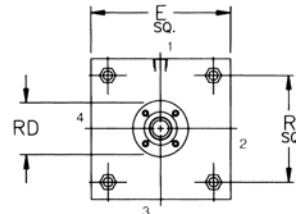

3-1/4" Through 6"

Bore	Rod	E	EE	F	G	J	K	LB	P	R	RD	WF	Y	ZB
1-1/2"	0.625	2.000	0.375	0.375	1.500	1.000	0.250	3.625	2.250	1.430	1.375	1.000	1.938	4.875
	1.000	2.000	0.375	0.375	1.500	1.000	0.250	3.625	2.103	1.430	2.000*	1.375	2.460	5.250
2"	0.625	2.500	0.375	0.375	1.500	1.000	0.313	3.625	2.250	1.840	1.375	1.000	1.938	4.938
	1.000	2.500	0.375	0.375	1.500	1.000	0.313	3.625	2.250	1.840	2.500*	1.375	2.313	5.313
2-1/2"	0.625	3.000	0.375	0.375	1.500	1.000	0.313	3.750	2.375	2.190	1.375	1.000	1.938	5.062
	1.000	3.000	0.375	0.375	1.500	1.000	0.313	3.750	2.375	2.190	3.000*	1.375	2.313	5.438
3-1/4"	1.000	3.750	0.500	0.625	1.750	1.250	0.375	4.250	2.625	2.760	2.706	1.375	2.438	6.000
	1.375	3.750	0.500	0.625	1.750	1.250	0.375	4.250	2.625	2.760	3.125	1.625	2.688	6.250
4"	1.000	4.500	0.500	0.625	1.750	1.250	0.375	4.250	2.625	3.320	2.706	1.375	2.438	6.000
	1.375	4.500	0.500	0.625	1.750	1.250	0.375	4.250	2.625	3.320	3.125	1.625	2.688	6.250
5"	1.000	5.500	0.500	0.625	1.750	1.250	0.500	4.500	2.875	4.100	2.706	1.375	2.438	6.375
	1.375	5.500	0.500	0.625	1.750	1.250	0.500	4.500	2.875	4.100	3.125	1.625	2.688	6.625
6"	1.375	6.500	0.750	0.625	2.000	1.500	0.500	5.000	3.125	4.880	3.125	1.625	2.813	7.125
	1.750	6.500	0.750	0.750	2.000	1.500	0.500	5.000	3.125	4.880	3.788	1.875	3.063	7.375

* Uses a full-face bushing retainer.

Dimensions: Inches

Standard and Optional Rod Ends

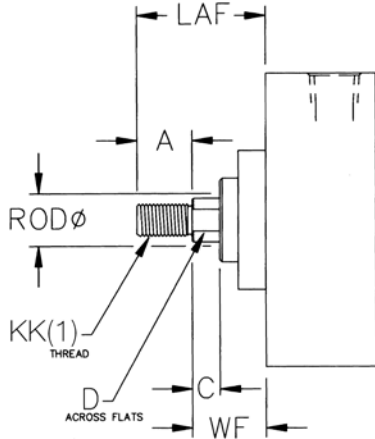

Style #1 (Standard Male)

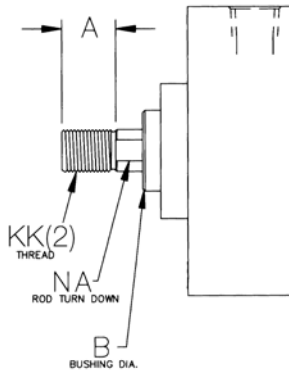

Style #2 (Optional Male)

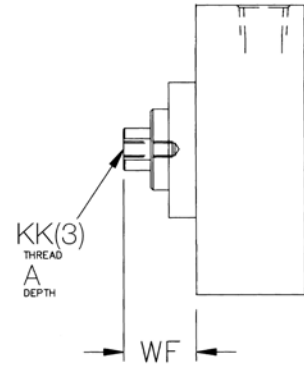

Style #3 (Optional Female)

Bore	Rod	KK(1)	KK(2)	KK(3)	A	B	C	D	NA	LAF	WF
1-1/2"	0.625	7/16-20	1/2-20	7/16-20	0.750	1.125	0.375	0.500	0.585	1.750	1.000
	1.000	3/4-16	7/8-14	3/4-16	1.125	1.500	0.500	0.813	0.960	2.500	1.375
2"	0.625	7/16-20	1/2-20	7/16-20	0.750	1.125	0.375	0.500	0.585	1.750	1.000
	1.000	3/4-16	7/8-14	3/4-16	1.125	1.500	0.500	0.813	0.960	2.500	1.375
2-1/2"	0.625	7/16-20	1/2-20	7/16-20	0.750	1.125	0.375	0.500	0.585	1.750	1.000
	1.000	3/4-16	7/8-14	3/4-16	1.125	1.500	0.500	0.813	0.960	2.500	1.375
3-1/4"	1.000	3/4-16	7/8-14	3/4-16	1.125	1.500	0.500	0.813	0.960	2.500	1.375
	1.375	1-14	1 1/4-12	1-14	1.625	2.000	0.625	1.125	1.313	3.250	1.625
4"	1.000	3/4-16	7/8-14	3/4-16	1.125	1.500	0.500	0.813	0.960	2.500	1.375
	1.375	1-14	1 1/4-12	1-14	1.625	2.000	0.625	1.125	1.313	3.250	1.625
5"	1.000	3/4-16	7/8-14	3/4-16	1.125	1.500	0.500	0.813	0.960	2.500	1.375
	1.375	1-14	1 1/4-12	1-14	1.625	2.000	0.625	1.125	1.313	3.250	1.625
6"	1.375	1-14	1 1/4-12	1-14	1.625	2.000	0.625	1.125	1.313	3.250	1.625
	1.750	1 1/4-12	1 1/2-12	1 1/4-12	2.000	2.375	0.750	1.500	1.688	3.875	1.875

Male Coupling Rod End

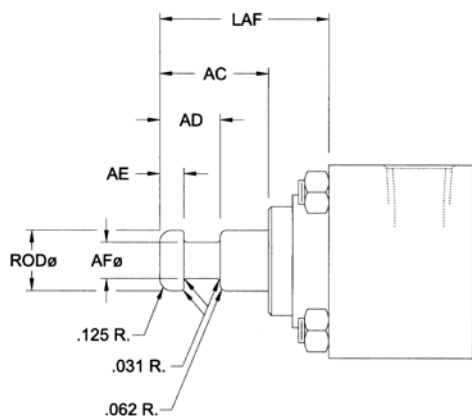

U = Male Coupling Rod End Standard Rod Diameter
V = Male Coupling Rod End Oversized Rod Diameter

Dimensions: Inches

Bore	Rod	AC	AD	AE	AF	LAF
1-1/2", 2", 2-1/2"	5/8"	1.125	0.625	0.250	0.375	1.750
	1"	1.625	0.938	0.375	0.688	2.500
3-1/4", 4", 5"	1"	1.500	0.938	0.375	0.688	2.375
	1 3/8"	1.750	1.062	0.375	0.875	2.750
6"	1 3/8"	1.750	1.062	0.375	0.875	2.750
	1 3/4"	2.000	1.313	0.500	1.125	3.125

Dimensions: Inches

Flange Mounts

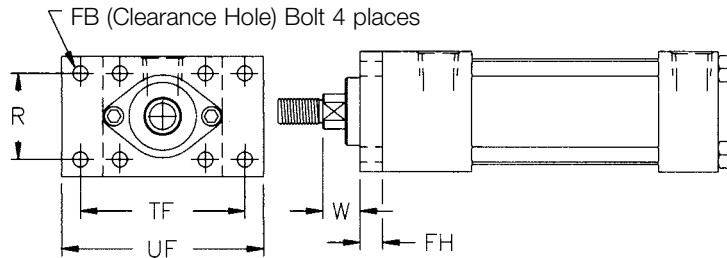

Mount Code F1 NFPA MF1

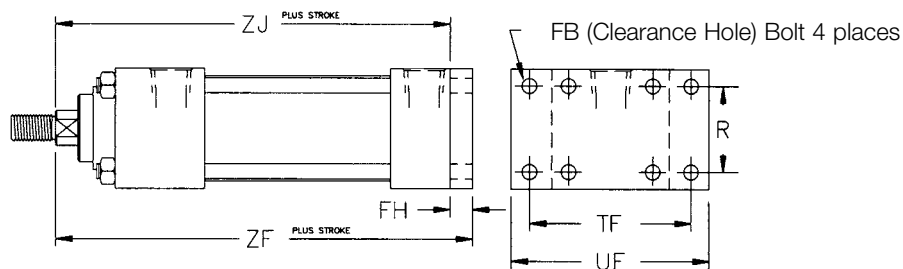

Mount Code F2 NFPA MF2

NOTE: This drawing represents 1-1/2" through 2-1/2" bore rod bushing retainer configuration.

Bore	Rod	FB	FH	R	TF	UF	W	ZJ	ZF
1-1/2"	0.625	0.313	0.375	1.430	2.750	3.375	0.625	4.625	5.000
	1.000	0.313	0.375	1.430	2.750	3.375	1.000	5.000	5.375
2"	0.625	0.375	0.375	1.840	3.375	4.125	0.625	4.625	5.000
	1.000	0.375	0.375	1.840	3.375	4.125	1.000	5.000	5.375
2-1/2"	0.625	0.375	0.375	2.190	3.875	4.625	0.625	4.750	5.125
	1.000	0.375	0.375	2.190	3.875	4.625	1.000	5.125	5.500
3-1/4"	1.000	0.438	0.625	2.760	4.688	5.500	0.750	5.625	6.250
	1.375	0.438	0.625	2.760	4.688	5.500	1.000	5.875	6.500
4"	1.000	0.438	0.625	3.320	5.438	6.250	0.750	5.625	6.250
	1.375	0.438	0.625	3.320	5.438	6.250	1.000	5.875	6.500
5"	1.000	0.563	0.625	4.100	6.625	7.625	0.750	5.875	6.500
	1.375	0.563	0.625	4.100	6.625	7.625	1.000	6.125	6.750
6"	1.375	0.563	0.750	4.880	7.625	8.625	0.875	6.625	7.375
	1.750	0.563	0.750	4.880	7.625	8.625	1.125	6.875	7.625

Dimensions: Inches

Clevis Mounts

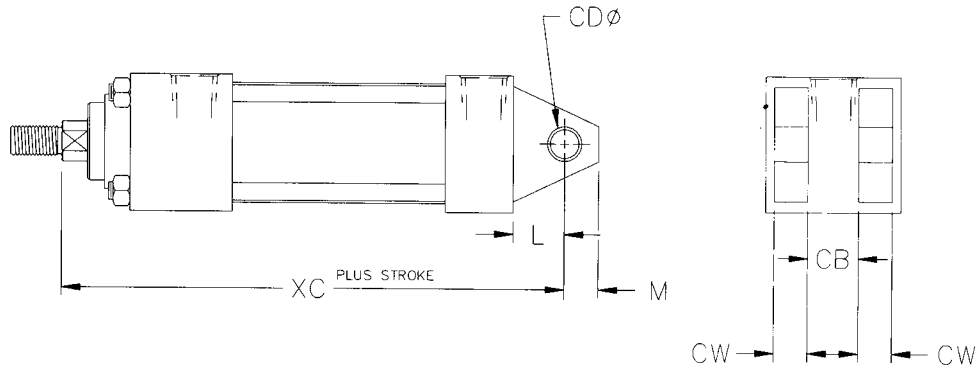

Mount Code P1 NFA MP1

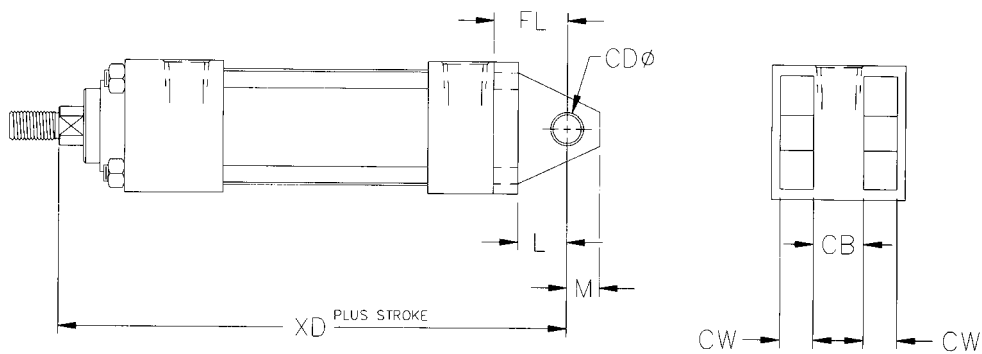

Mount Code P2 NFA MP2

Bore	Rod	CB	CD	CW	FL	L	M	XC	XD
1-1/2"	0.625	0.750	0.500	0.500	1.125	0.750	0.500	5.375	5.750
	1.000	0.750	0.500	0.500	1.125	0.750	0.500	5.750	6.125
2"	0.625	0.750	0.500	0.500	1.125	0.750	0.500	5.375	5.750
	1.000	0.750	0.500	0.500	1.125	0.750	0.500	5.750	6.125
2-1/2"	0.625	0.750	0.500	0.500	1.125	0.750	0.500	5.500	5.875
	1.000	0.750	0.500	0.500	1.125	0.750	0.500	5.875	6.250
3-1/4"	1.000	1.250	0.750	0.625	1.875	1.250	0.750	6.875	7.500
	1.375	1.250	0.750	0.625	1.875	1.250	0.750	7.125	7.750
4"	1.000	1.250	0.750	0.625	1.875	1.250	0.750	6.875	7.500
	1.375	1.250	0.750	0.625	1.875	1.250	0.750	7.125	7.750
5"	1.000	1.250	0.750	0.625	1.875	1.250	0.750	7.125	7.750
	1.375	1.250	0.750	0.625	1.875	1.250	0.750	7.375	8.000
6"	1.375	1.500	1.000	0.750	2.250	1.500	1.000	8.125	8.875
	1.750	1.500	1.000	0.750	2.250	1.500	1.000	8.375	9.125

Dimensions: Inches

Eye Mounts

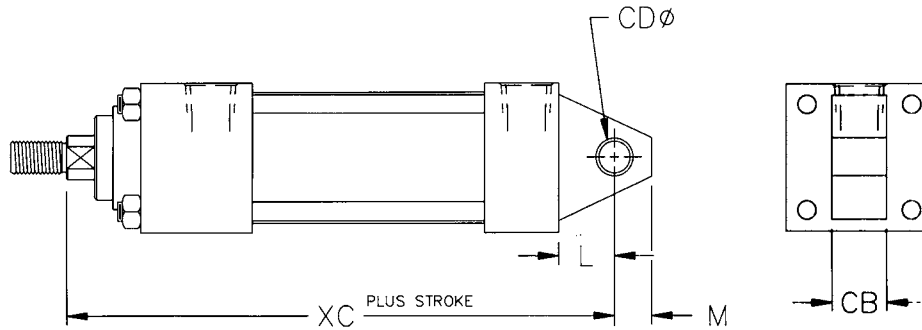

Mount Code P3 NFPA MP3

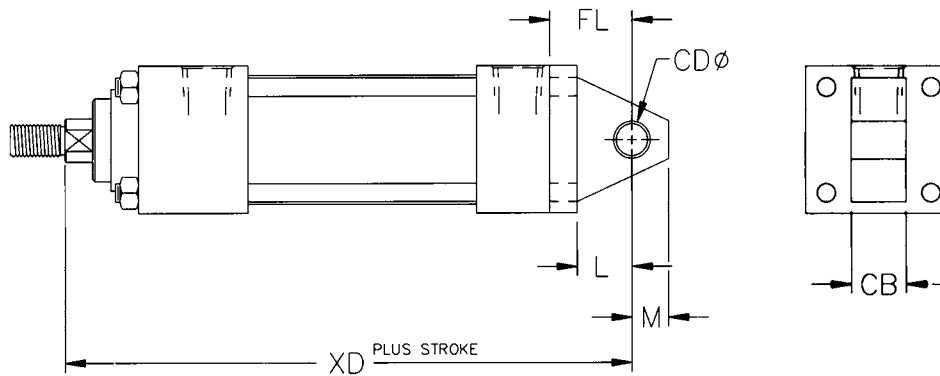

Mount Code P4 NFPA MP4

Bore	Rod	CB	CD	FL	L	M	XC	XD
1-1/2"	0.625	0.750	0.500	1.125	0.750	0.500	5.375	5.750
	1.000	0.750	0.500	1.125	0.750	0.500	5.750	6.125
2"	0.625	0.750	0.500	1.125	0.750	0.500	5.375	5.750
	1.000	0.750	0.500	1.125	0.750	0.500	5.750	6.125
2-1/2"	0.625	0.750	0.500	1.125	0.750	0.500	5.500	5.875
	1.000	0.750	0.500	1.125	0.750	0.500	5.875	6.250
3-1/4"	1.000	1.250	0.750	1.875	1.250	0.750	6.875	7.500
	1.375	1.250	0.750	1.875	1.250	0.750	7.125	7.750
4"	1.000	1.250	0.750	1.875	1.250	0.750	6.875	7.500
	1.375	1.250	0.750	1.875	1.250	0.750	7.125	7.750
5"	1.000	1.250	0.750	1.875	1.250	0.750	7.125	7.750
	1.375	1.250	0.750	1.875	1.250	0.750	7.375	8.000
6"	1.375	1.500	1.000	2.250	1.500	1.000	8.125	8.875
	1.750	1.500	1.000	2.250	1.500	1.000	8.375	9.125

Dimensions: Inches

Angle Mount

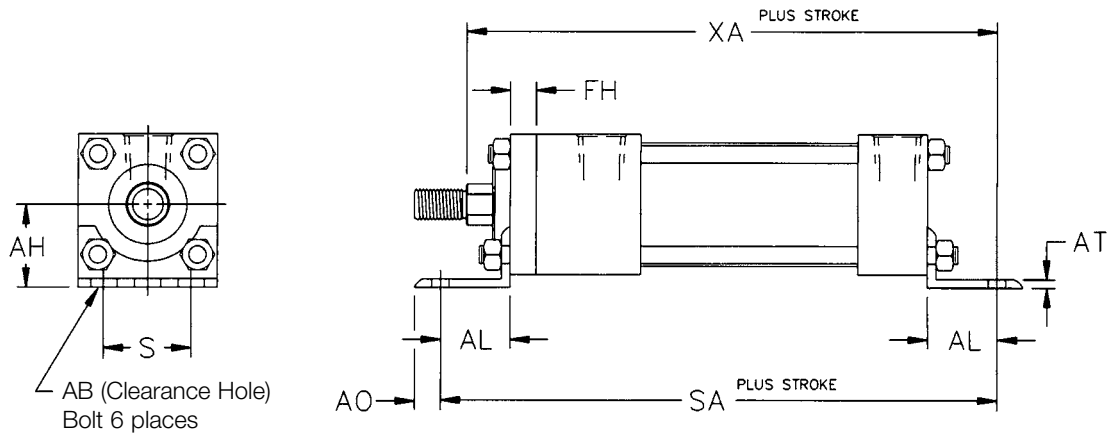

Mount Code S1 NFFPA MS1

Bore	Rod	AB	AH	AL	AO	AT	FH	S	SA	XA
1-1/2"	0.625	0.375	1.188	1.000	0.375	0.125	0.375	1.250	6.000	5.625
	1.000	0.375	1.188	1.000	0.375	0.125	0.375	1.250	6.000	6.000
2"	0.625	0.375	1.438	1.000	0.375	0.125	0.375	1.750	6.000	5.625
	1.000	0.375	1.438	1.000	0.375	0.125	0.375	1.750	6.000	6.000
2-1/2"	0.625	0.375	1.625	1.000	0.375	0.125	0.375	2.250	6.125	5.750
	1.000	0.375	1.625	1.000	0.375	0.125	0.375	2.250	6.125	6.125
3-1/4"	1.000	0.500	1.938	1.250	0.500	0.125	0.625	2.750	7.375	6.875
	1.375	0.500	1.938	1.250	0.500	0.125	0.625	2.750	7.375	7.125
4"	1.000	0.500	2.250	1.250	0.500	0.125	0.625	3.500	7.375	6.875
	1.375	0.500	2.250	1.250	0.500	0.125	0.625	3.500	7.375	7.125
5"	1.000	0.625	2.750	1.375	0.625	0.188	0.625	4.250	7.875	7.250
	1.375	0.625	2.750	1.375	0.625	0.188	0.625	4.250	7.875	7.500
6"	1.375	0.750	3.250	1.375	0.625	0.188	0.750	5.250	8.500	8.000
	1.750	0.750	3.250	1.375	0.625	0.188	0.750	5.250	8.500	8.250

Dimensions: Inches

Side Lug Mount

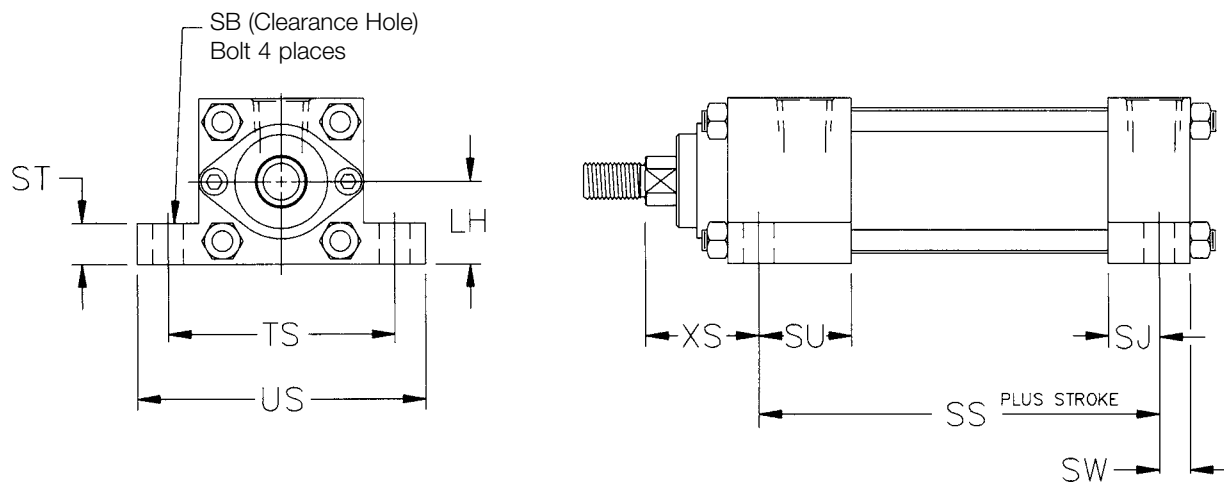

Mount Code S2 NFPA MS2

Bore	Rod	LH	SB	SJ	SS	ST	SU	SW	TS	US	XS
1-1/2"	0.625	1.000	0.375	0.625	2.875	0.500	1.125	0.375	2.750	3.500	1.375
	1.000	1.000	0.375	0.625	2.875	0.500	1.125	0.375	2.750	3.500	1.750
2"	0.625	1.250	0.375	0.625	2.875	0.500	1.125	0.375	3.250	4.000	1.375
	1.000	1.250	0.375	0.625	2.875	0.500	1.125	0.375	3.250	4.000	1.750
2-1/2"	0.625	1.500	0.375	0.625	3.000	0.500	1.125	0.375	3.750	4.500	1.375
	1.000	1.500	0.375	0.625	3.000	0.500	1.125	0.375	3.750	4.500	1.750
3-1/4"	1.000	1.875	0.500	0.750	3.250	0.750	1.250	0.500	4.750	5.750	1.875
	1.375	1.875	0.500	0.750	3.250	0.750	1.250	0.500	4.750	5.750	2.125
4"	1.000	2.250	0.500	0.750	3.250	0.750	1.250	0.500	5.500	6.500	1.875
	1.375	2.250	0.500	0.750	3.250	0.750	1.250	0.500	5.500	6.500	2.125
5"	1.000	2.750	0.750	0.563	3.125	1.000	1.063	0.688	6.875	8.250	2.063
	1.375	2.750	0.750	0.563	3.125	1.000	1.063	0.688	6.875	8.250	2.313
6"	1.375	3.250	0.750	0.813	3.625	1.000	1.313	0.688	7.875	9.250	2.313
	1.750	3.250	0.750	0.813	3.625	1.000	1.313	0.688	7.875	9.250	2.563

Dimensions: Inches

Bottom Tap Mount

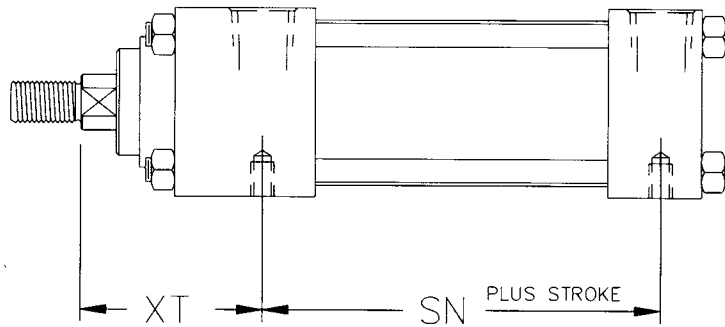
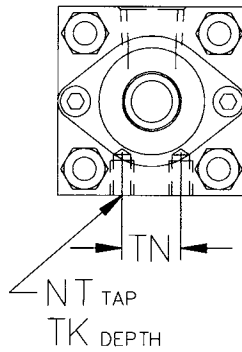

Mount Code S4 NFPA MS4

Bore	Rod	NT	TK	TN	SN	XT
1-1/2"	0.625	1/4-20	0.375	0.625	2.250	1.938
	1.000	1/4-20	0.313	0.625	2.250	2.313
2"	0.625	5/16-18	0.500	0.875	2.250	1.938
	1.000	5/16-18	0.500	0.875	2.250	2.313
2-1/2"	0.625	3/8-16	0.625	1.250	2.375	1.938
	1.000	3/8-16	0.625	1.250	2.375	2.313
3-1/4"	1.000	1/2-13	0.750	1.500	2.625	2.438
	1.375	1/2-13	0.750	1.500	2.625	2.688
4"	1.000	1/2-13	0.750	2.063	2.625	2.438
	1.375	1/2-13	0.750	2.063	2.625	2.688
5"	1.000	5/8-11	1.000	2.688	2.875	2.438
	1.375	5/8-11	1.000	2.688	2.875	2.688
6"	1.375	3/4-10	1.125	3.250	3.125	2.813
	1.750	3/4-10	1.125	3.250	3.125	3.063

Dimensions: Inches

Extended Tie Rod Mounts

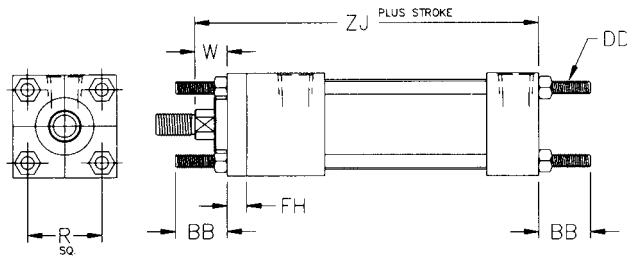

Mount Code X1 NFPA MX1

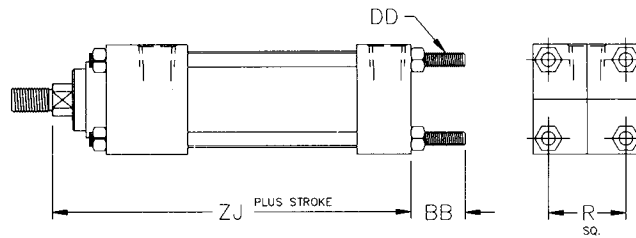

Mount Code X2 NFPA MX2

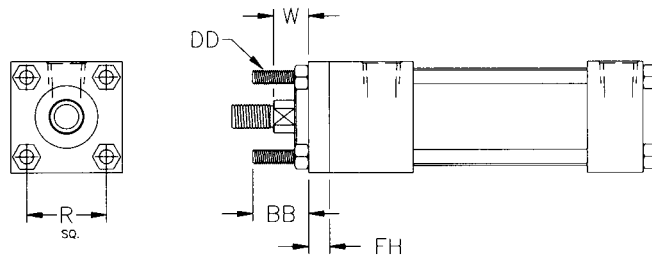

Mount Code X3 NFPA MX3

Bore	Rod	BB	DD	FH	R	W	ZJ
1-1/2"	0.625	1.000	1/4-28	0.375	1.430	0.625	4.625
	1.000	1.000	1/4-28	0.375	1.430	1.000	5.000
2"	0.625	1.125	5/16-24	0.375	1.840	0.625	4.625
	1.000	1.125	5/16-24	0.375	1.840	1.000	5.000
2-1/2"	0.625	1.125	5/16-24	0.375	2.190	0.625	4.750
	1.000	1.125	5/16-24	0.375	2.190	1.000	5.125
3-1/4"	1.000	1.375	3/8-24	0.625	2.760	0.750	5.625
	1.375	1.375	3/8-24	0.625	2.760	1.000	5.875
4"	1.000	1.375	3/8-24	0.625	3.320	0.750	5.625
	1.375	1.375	3/8-24	0.625	3.320	1.000	5.875
5"	1.000	1.813	1/2-20	0.625	4.100	0.750	5.875
	1.375	1.813	1/2-20	0.625	4.100	1.000	6.125
6"	1.375	1.813	1/2-20	0.750	4.880	0.875	6.625
	1.750	1.813	1/2-20	0.750	4.880	1.125	6.875

Dimensions: Inches

Trunnion Mounts

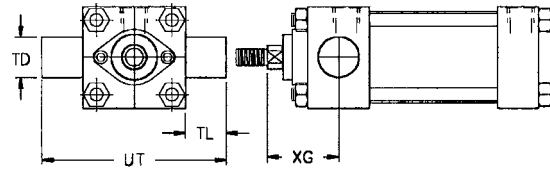

Mount Code T1 (Fixed Steel Trunnion Ears)
Mount Code T6 (Removable Aluminum Trunnion Head)

NFPA MT1

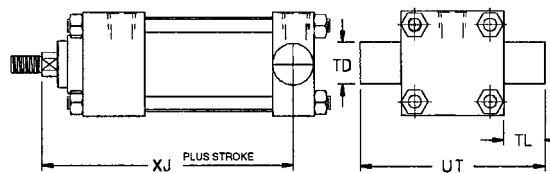

Mount Code T2 (Fixed Steel Trunnion Ears)
Mount Code T7 (Removable Aluminum Trunnion Head)

NFPA MT2

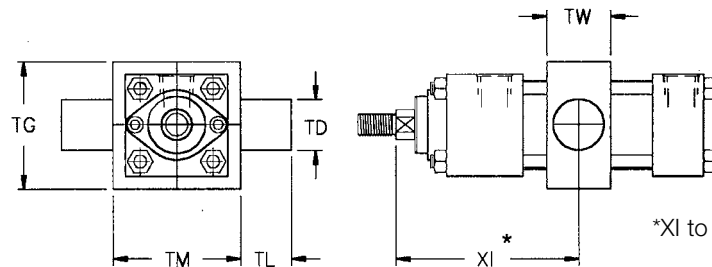

*XI to be specified by customer

Mount Code T4

NFPA MT4

Bore	Rod	TD	TG	TL	TM	TW	UT	XG	XI (Min.)	XJ
1-1/2"	0.625	1.000	2.500	1.000	2.500	1.250	4.000	1.750	3.125	4.125
	1.000	1.000	2.500	1.000	2.500	1.250	4.000	2.125	3.500	4.500
2"	0.625	1.000	3.000	1.000	3.000	1.500	4.500	1.750	3.250	4.125
	1.000	1.000	3.000	1.000	3.000	1.500	4.500	2.125	3.625	4.500
2-1/2"	0.625	1.000	3.500	1.000	3.500	1.500	5.000	1.750	3.250	4.250
	1.000	1.000	3.500	1.000	3.500	1.500	5.000	2.125	3.625	4.625
3-1/4"	1.000	1.000	4.250	1.000	4.500	2.000	5.750	2.250	4.125	5.000
	1.375	1.000	4.250	1.000	4.500	2.000	5.750	2.500	4.375	5.250
4"	1.000	1.000	5.000	1.000	5.250	2.000	6.500	2.250	4.125	5.000
	1.375	1.000	5.000	1.000	5.250	2.000	6.500	2.500	4.375	5.250
5"	1.000	1.000	6.000	1.000	6.250	2.000	7.500	2.250	4.125	5.250
	1.375	1.000	6.000	1.000	6.250	2.000	7.500	2.500	4.375	5.500
6"	1.375	1.375	7.000	1.375	7.625	2.500	9.250	2.625	4.875	5.875
	1.750	1.375	7.000	1.375	7.625	2.500	9.250	2.875	5.125	6.125

Dimensions: Inches

Sleeve Nut Mount

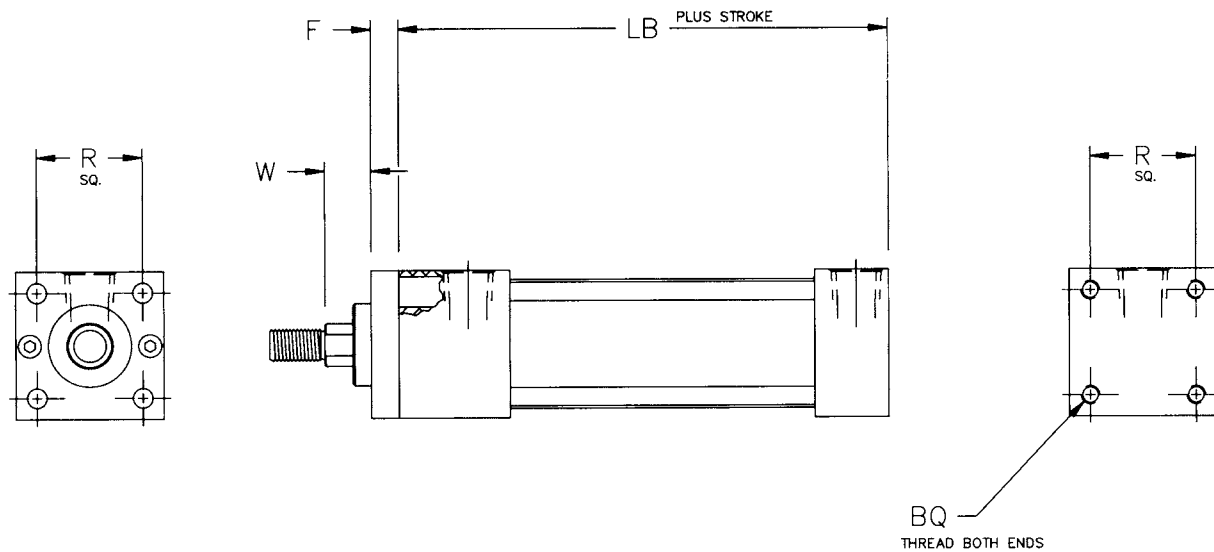

Mount Code SN

Bore	Rod	BQ	F	LB	R	W
1-1/2"	0.625	1/4-28	0.375	3.625	1.430	0.625
	1.000	1/4-28	0.375	3.625	1.430	1.000
2"	0.625	5/16-24	0.375	3.625	1.840	0.625
	1.000	5/16-24	0.375	3.625	1.840	1.000
2-1/2"	0.625	5/16-24	0.375	3.750	2.190	0.625
	1.000	5/16-24	0.625	3.750	2.190	1.000
3-1/4"	1.000	3/8-24	0.625	4.250	2.760	0.750
	1.375	3/8-24	0.625	4.250	2.760	1.000
4"	1.000	3/8-24	0.625	4.250	3.320	0.750
	1.375	3/8-24	0.625	4.250	3.320	1.000
5"	1.000	1/2-20	0.625	4.500	4.100	0.750
	1.375	1/2-20	0.625	4.500	4.100	1.000
6"	1.375	1/2-20	0.625	5.000	4.880	1.000
	1.750	1/2-20	0.750	5.000	4.880	1.125

Dimensions: Inches

Double Rod End

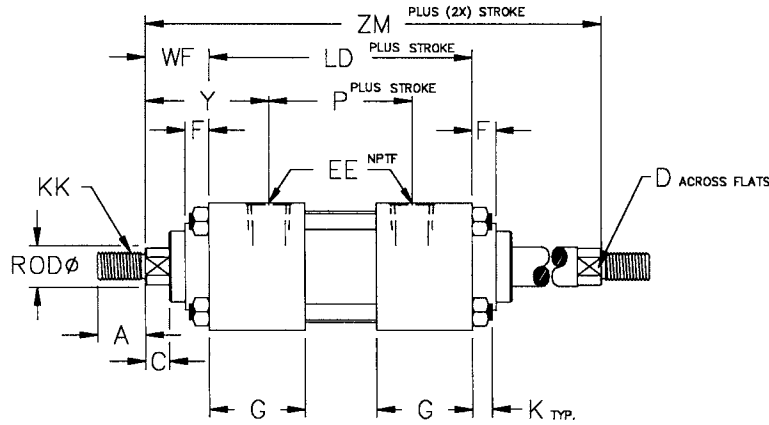

Order as "DA" Option

NFPA MDXO

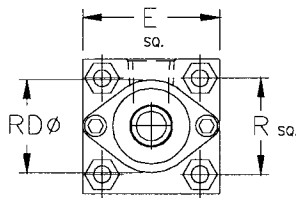

1 1/2" Through 2 1/2"

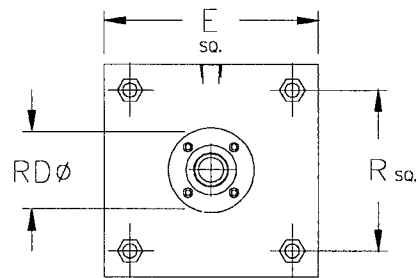

3 1/4" Through 6"

Bore	Rod	A	C	D	E	EE	F	G	K	KK	LD	P	R	SN	SS	RD	WF	Y	ZM
1-1/2"	0.625	0.750	0.375	0.500	2.000	0.375	0.375	1.500	0.250	7/16-20	4.125	2.250	1.430	2.250	3.375	1.375	1.000	1.938	6.125
	1.000	1.125	0.500	0.813	2.000	0.250	0.375	1.500	0.250	3/4-16	4.125	1.955	1.430	2.250	3.375	2.000*	1.375	2.460	6.875
2"	0.625	0.750	0.375	0.500	2.500	0.375	0.375	1.500	0.313	7/16-20	4.125	2.250	1.840	2.250	3.375	1.375	1.000	1.938	6.125
	1.000	1.125	0.500	0.813	2.500	0.375	0.375	1.500	0.313	3/4-16	4.125	2.250	1.840	2.250	3.375	2.500*	1.375	2.313	6.875
2-1/2"	0.625	0.750	0.375	0.500	3.000	0.375	0.375	1.500	0.313	7/16-20	4.250	2.375	2.190	2.375	3.500	1.375	1.000	1.938	6.250
	1.000	1.125	0.500	0.813	3.000	0.375	0.375	1.500	0.313	3/4-16	4.250	2.375	2.190	2.375	3.500	3.000*	1.375	2.313	7.000
3-1/4"	1.000	1.125	0.500	0.813	3.750	0.500	0.625	1.750	0.375	3/4-16	4.750	2.625	2.760	2.625	3.750	2.706	1.375	2.438	7.500
	1.375	1.625	0.625	1.125	3.750	0.500	0.625	1.750	0.375	1-14	4.750	2.625	2.760	2.625	3.750	3.125	1.625	2.688	8.000
4"	1.000	1.125	0.500	0.813	4.500	0.500	0.625	1.750	0.375	3/4-16	4.750	2.625	3.320	2.625	3.750	2.706	1.375	2.438	7.500
	1.375	1.625	0.625	1.125	4.500	0.500	0.625	1.750	0.375	1-14	4.750	2.625	3.320	2.625	3.750	3.125	1.625	2.688	8.000
5"	1.000	1.125	0.500	0.813	5.500	0.500	0.625	1.750	0.500	3/4-16	5.000	2.875	4.100	2.875	3.625	2.706	1.375	2.438	7.750
	1.375	1.625	0.625	1.125	5.500	0.500	0.625	1.750	0.500	1-14	5.000	2.875	4.100	2.875	3.625	3.125	1.625	2.688	8.250
6"	1.375	1.625	0.625	1.125	6.500	0.750	0.625	2.000	0.500	1-14	5.000	3.125	4.880	3.125	4.125	3.125	1.625	2.813	8.750
	1.750	2.000	0.750	1.500	6.500	0.750	0.750	2.000	0.500	1 1/4-12	5.000	3.125	4.880	3.125	4.125	3.788	1.875	3.063	9.250

*Uses a full-face bushing retainer.

Dimensions: Inches

Tandem Cylinders

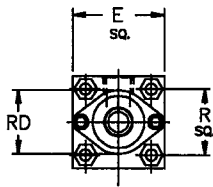
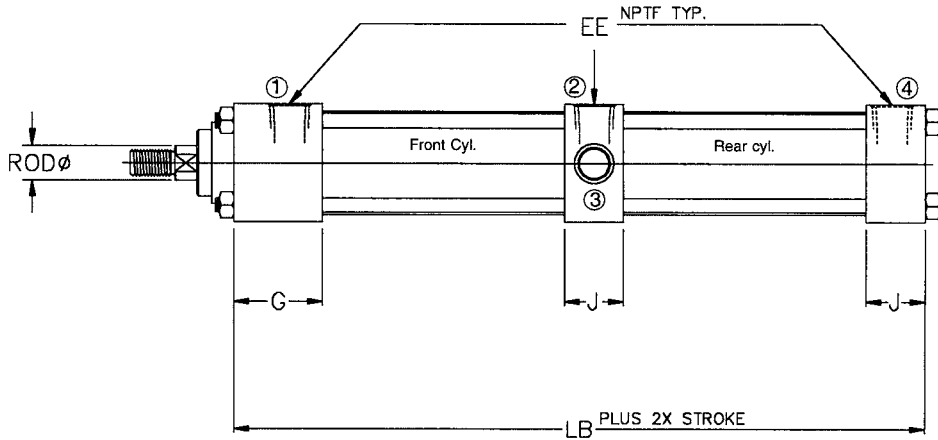

1-1/2" Through 2-1/2"

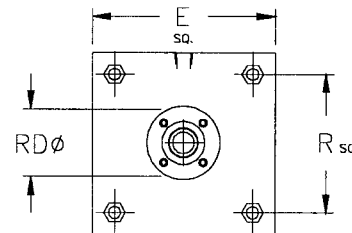

3-1/4" Through 6"

This configuration provides approximately twice the force of an equivalent basic double acting cylinder. Two pistons are attached to a common piston rod. Ports 2 and 4 are pressurized to roughly double the extend force. Ports 1 and 3 are pressurized to double the retract force.

Bore	Rod	E	EE	G	J	LB	R	RD
1-1/2"	0.625	2.000	3/8	1.500	1.000	5.750	1.430	1.375
	1.000	N/A	N/A	N/A	N/A	N/A	N/A	N/A
2"	0.625	2.500	3/8	1.500	1.000	5.750	1.840	1.375
	1.000	2.500	3/8	1.500	1.000	5.750	1.840	2.000
2-1/2"	0.625	3.000	3/8	1.500	1.000	6.000	2.190	1.375
	1.000	3.000	3/8	1.500	1.000	6.000	2.190	3.000
3-1/4"	1.000	3.750	1/2	1.750	1.250	6.750	2.760	2.706
	1.375	3.750	1/2	1.750	1.250	6.750	2.760	3.125
4"	1.000	4.500	1/2	1.750	1.250	6.750	3.320	2.706
	1.375	4.500	1/2	1.750	1.250	6.750	3.320	3.125
5"	1.000	5.500	1/2	1.750	1.250	7.250	4.100	2.706
	1.375	5.500	1/2	1.750	1.250	7.250	4.100	3.125
6"	1.375	6.500	3/4	2.000	1.500	8.000	4.880	3.125
	1.750	6.500	3/4	2.000	1.500	8.000	4.880	3.788

Dimensions: Inches

Multi-Position Cylinders

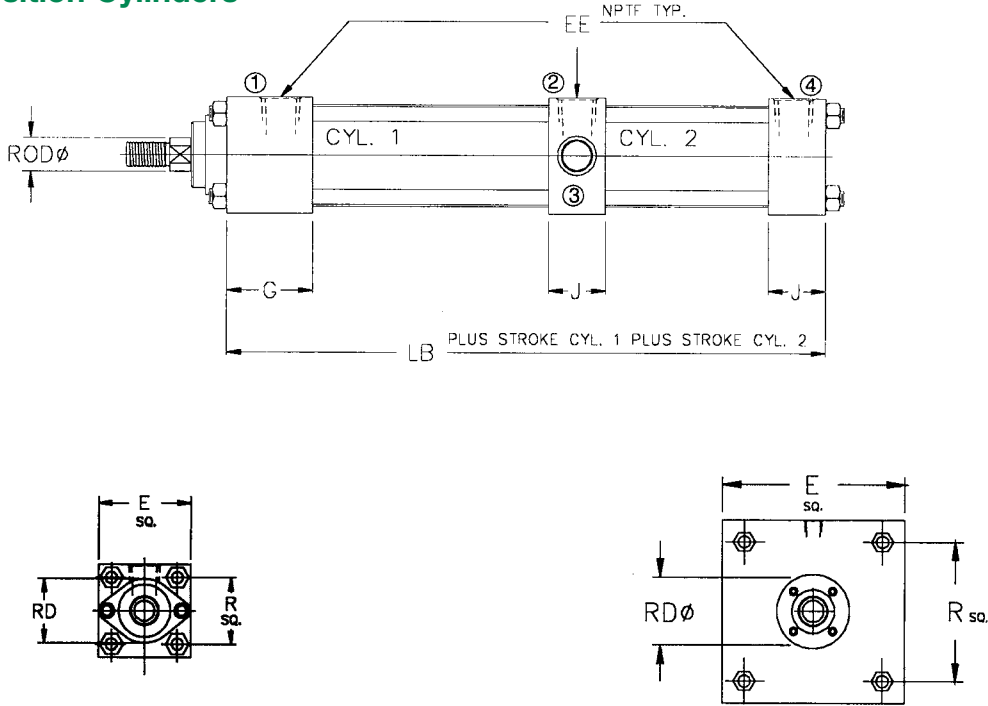

1-1/2" Through 2 1/2"

3-1/4" Through 6"

Multi-position cylinders look similar to tandem cylinders. However, in this cylinder the rear and front piston rods are separate. The stroke from full retract to the intermediate extend point is set by the stroke of cylinder #2. The total stroke from full retract to full extend is set by the stroke cylinder #1. Full extend or retract is achieved by pressurizing ports 2 or 1 respectively with ports 3 and 4 vented. An intermediate position is achieved by pressurizing port 4 with the other ports vented or by pressurizing both ports 1 and 4. With 1 and 4 pressurized, the rod is more positively held in the intermediate position.

Bore	Rod	E	EE	G	J	LB	R	RD
1-1/2"	0.625	2.000	3/8	1.500	1.000	5.750	1.430	1.375*
	1.000	N/A	N/A	N/A	N/A	N/A	N/A	N/A
2"	0.625	2.500	3/8	1.500	1.000	5.750	1.840	1.375
	1.000	2.500	3/8	1.500	1.000	5.750	1.840	2.000*
2-1/2"	0.625	3.000	3/8	1.500	1.000	6.000	2.190	1.375
	1.000	3.000	3/8	1.500	1.000	6.000	2.190	3.000*
3-1/4"	1.000	3.750	1/2	1.750	1.250	6.750	2.760	2.706
	1.375	3.750	1/2	1.750	1.250	6.750	2.760	3.125
4"	1.000	4.500	1/2	1.750	1.250	6.750	3.320	2.706
	1.375	4.500	1/2	1.750	1.250	6.750	3.320	3.125
5"	1.000	5.500	1/2	1.750	1.250	7.250	4.100	2.706
	1.375	5.500	1/2	1.750	1.250	7.250	4.100	3.125
6"	1.375	6.500	3/4	2.000	1.500	8.000	4.880	3.125
	1.750	6.500	3/4	2.000	1.500	8.000	4.880	3.788

*Uses a full-face bushing retainer.

Dimensions: Inches

Back to Back Cylinders

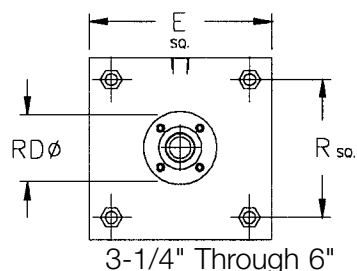
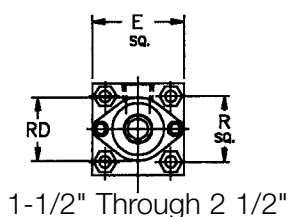
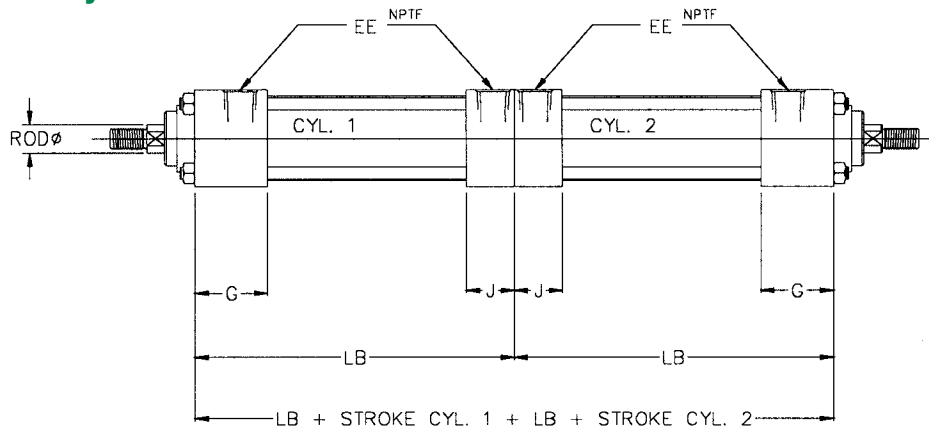

This configuration is two cylinders mounted back to back. Each cylinder can be operated independently. The cylinders can have the same stroke or different strokes. This configuration enables you to have four combinations of rods extended or retracted.

Bore	Rod	E	EE	G	J	LB	R	RD
1-1/2"	0.625	2.000	3/8	1.500	1.000	3.625	1.430	1.375
	1.000	N/A	N/A	N/A	N/A	3.625	1.430	2.000*
2"	0.625	2.500	3/8	1.500	1.000	3.625	1.840	1.375
	1.000	2.500	3/8	1.500	1.000	3.625	1.840	2.500
2-1/2"	0.625	3.000	3/8	1.500	1.000	3.750	2.190	1.375
	1.000	3.000	3/8	1.500	1.000	3.750	2.190	3.000*
3-1/4"	1.000	3.750	1/2	1.750	1.250	4.250	2.760	2.706
	1.375	3.750	1/2	1.750	1.250	4.250	2.760	3.125
4"	1.000	4.500	1/2	1.750	1.250	4.250	3.320	2.706
	1.375	4.500	1/2	1.750	1.250	4.250	3.320	3.125
5"	1.000	5.500	1/2	1.750	1.250	4.500	4.100	2.706
	1.375	5.500	1/2	1.750	1.250	4.500	4.100	3.125
6"	1.375	6.500	3/4	2.000	1.500	5.000	4.880	3.125
	1.750	6.500	3/4	2.000	1.500	5.000	4.880	3.788

*Uses a full-face bushing retainer.

Air-Oil Tanks

The Numatics Air-Oil Tank offers a way to convert available (shop) air pressure into hydraulic pressure. Compressed air is applied directly to the oil that is in the air-oil tank. In turn, it is converted into hydraulic pressure. Note that the pressure is converted at a 1 to 1 ratio. For example, 90 psi air produces 90 psi hydraulic pressure.

All Numatics Air-Oil Tanks have a sight level gauge, which shows the oil level. They also contain two fluid flow baffles. The top baffle disperses the incoming air over the surface of the oil in an effort to inhibit agitation. The bottom baffle ensures a smooth flow pattern. This will minimize oil turbulence and eliminate swirling. Swirling could cause the oil to be blown from the tank into atmosphere.

Air-Oil Tanks are used to assist in making the piston rod travel smooth and effortless, in turn, preventing unwanted chatter. Air-Oil Tanks are commonly used in slow speed applications. Fluid velocity in or out of the tank through standard ports should be less than 6 feet per second. Again, this will prevent the oil from being blown from the tank into atmosphere. Since each tank is designed for a specific port size, note that increasing the port size in an effort to decrease the fluid velocity is not recommended. Instead, a tank with a larger port should be selected.

Bore	Stroke (in) 4 Volume (in ³)	Stroke (in) 8 Volume (in ³)	Stroke (in) 12 Volume (in ³)	Stroke (in) 16 Volume (in ³)	Stroke (in) 20 Volume (in ³)	Stroke (in) 24 Volume (in ³)
2"	12.6	25.1	37.7	50.3	62.8	75.4
2-1/2"	19.6	39.3	58.9	78.5	98.2	117.8
3-1/4"	33.2	66.4	99.5	132.7	165.9	199.1
4"	50.3	100.5	150.8	201.1	251.3	301.6
5"	78.5	157.1	235.6	314.2	392.7	471.2
6"	113.1	226.2	339.3	452.4	565.5	678.6
8"	201.1	402.1	603.2	804.2	1005.3	1206.4

How to Order

F1 T L - 04 A 0 D - A AA 0

Mount

- E3* = Head Square
- E4* = Cap Square
- F1 = Front Flange
- F2 = Rear Flange
- S1 = Angle Mount
- S2 = Side Lug Mount
- S4 = Bottom Tap
- X0 = Basic No Mount
- X1 = Extended Tie Rod Both Ends
- X2 = Extended Tie Rod Cap
- X3 = Extended Tie Rod Head
- *Only Available for 8" Bore

Type

- T = Air-Oil Tank

Bore

- K = 1-1/2" R = 4"
- L = 2" T = 5"
- M = 2-1/2" U = 6"
- P = 3-1/4" W = 8"

Full Inches of Stroke

- 00 = 0" Stroke
- 01 = 1" Stroke
- 02 = 2" Stroke
- 03 = 3" Stroke
- 99 = 99" Stroke

Note: Consult factory for strokes greater than 99".

Magnet

- 0 = No Magnet

Options

- AA = No Options
- VA = FKM Seals
- VC = Volume Chamber

Cushions

- A = No Cushions

Ports

Position	1/8"	1/4"	3/8"	1/2"	3/4"
1	B	C	D	E	F
2	H	I	J	K	L
3	N	O	P	Q	R
4	T	U	V	W	X

Rod Code

- 0 = No Rod

Fractional Inches of Stroke

A = 0"	A = 1/2"
B = 1/16"	B = 9/16"
C = 1/8"	C = 5/8"
D = 3/16"	A = 11/16"
E = 1/4"	B = 3/4"
F = 5/16"	C = 13/16"
G = 3/8"	B = 7/8"
H = 7/16"	C = 15/16"

Dimensions: Inches

X0 Mount

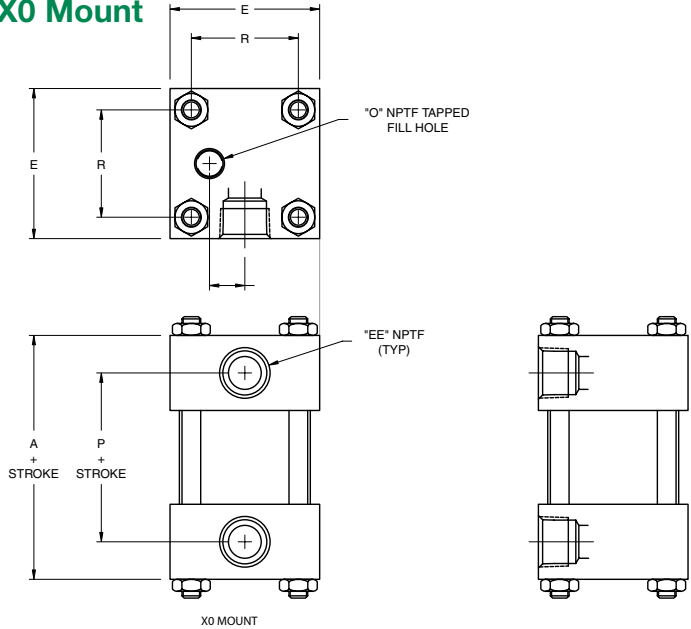

Bore	A	E	EE	M	O	P	R
2"	2.00	2.50	3/8	0.56	1/4	1.12	1.84
2-1/2"	2.00	3.00	3/8	0.69	1/4	1.12	2.19
3-1/4"	2.50	3.75	1/2	0.88	3/8	1.38	2.76
4"	2.50	4.50	1/2	0.88	3/8	1.38	3.32
5"	2.50	5.50	1/2	1.31	3/8	1.38	4.10
6"	3.00	6.50	1/2	1.31	3/8	1.63	4.88
8"	3.00	8.50	3/4	2.25	1/2	1.63	6.44

S4 Mount

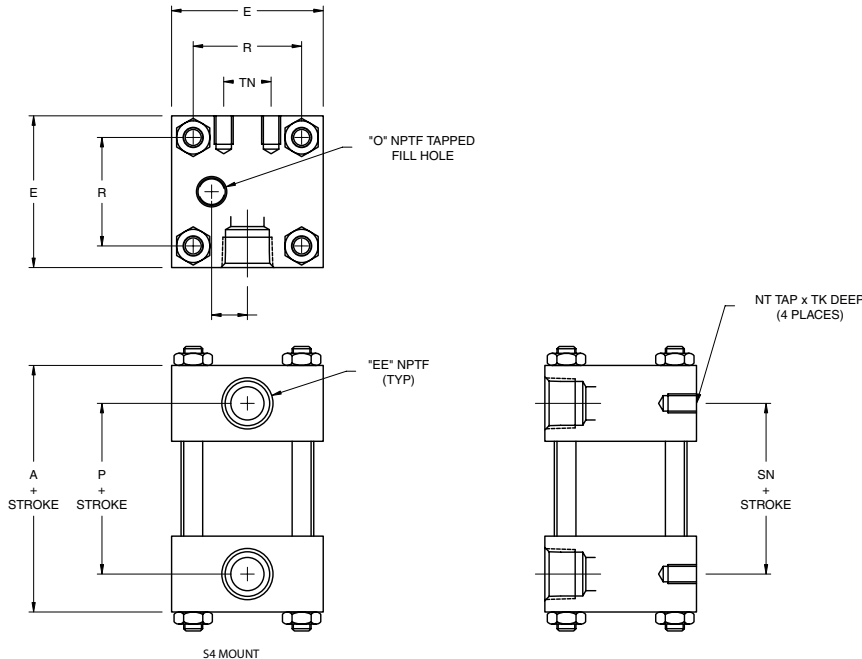

Bore	A	E	EE	M	O	P	R	NT	SN	TK	TN
2"	2.00	2.50	3/8	0.56	1/4	1.12	1.84	5/16-18 UNC-2B	1.13	0.28	0.88
2-1/2"	2.00	3.00	3/8	0.69	1/4	1.12	2.19	3/8-16 UNC-2B	1.13	0.28	1.25
3-1/4"	2.50	3.75	1/2	0.88	3/8	1.38	2.76	1/2-13 UNC-2B	1.37	0.25	1.50
4"	2.50	4.50	1/2	0.88	3/8	1.38	3.32	1/2-13 UNC-2B	1.37	0.50	2.06
5"	2.50	5.50	1/2	1.31	3/8	1.38	4.10	5/8-11 UNC-2B	1.37	1.00	2.69
6"	3.00	6.50	1/2	1.31	3/8	1.63	4.88	3/4-10 UNC-2B	1.63	0.94	3.25
8"	3.00	8.50	3/4	2.25	1/2	1.63	6.44	3/4-10 UNC-2B	1.63	0.94	4.50

Dimensions: Inches

S2 Mount

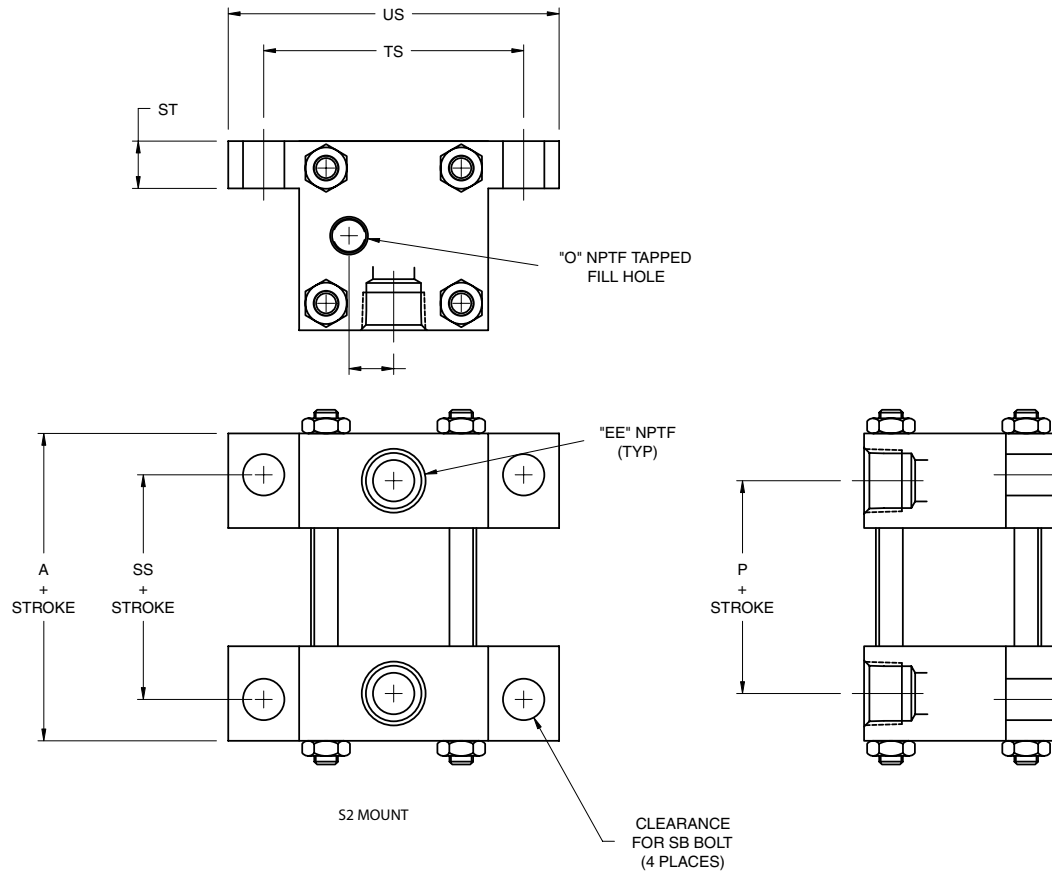

Bore	A	EE	M	O	P	SB	SS	ST	TS	US
2"	2.00	3/8	0.56	1/4	1.12	3/8	1.13	0.50	3.25	4.00
2-1/2"	2.00	3/8	0.69	1/4	1.12	3/8	1.13	0.50	3.75	4.50
3-1/4"	2.50	1/2	0.88	3/8	1.38	1/2	1.44	0.75	4.75	5.75
4"	2.50	1/2	0.88	3/8	1.38	1/2	1.44	0.75	5.50	6.50
5"	2.50	1/2	1.31	3/8	1.38	3/4	1.44	1.00	6.88	8.25
6"	3.00	1/2	1.31	3/8	1.63	3/4	1.69	1.00	7.88	9.25
8"	3.00	3/4	2.25	1/2	1.63	3/4	1.69	1.00	9.88	11.25

Dimensions: Inches

S1 Mount

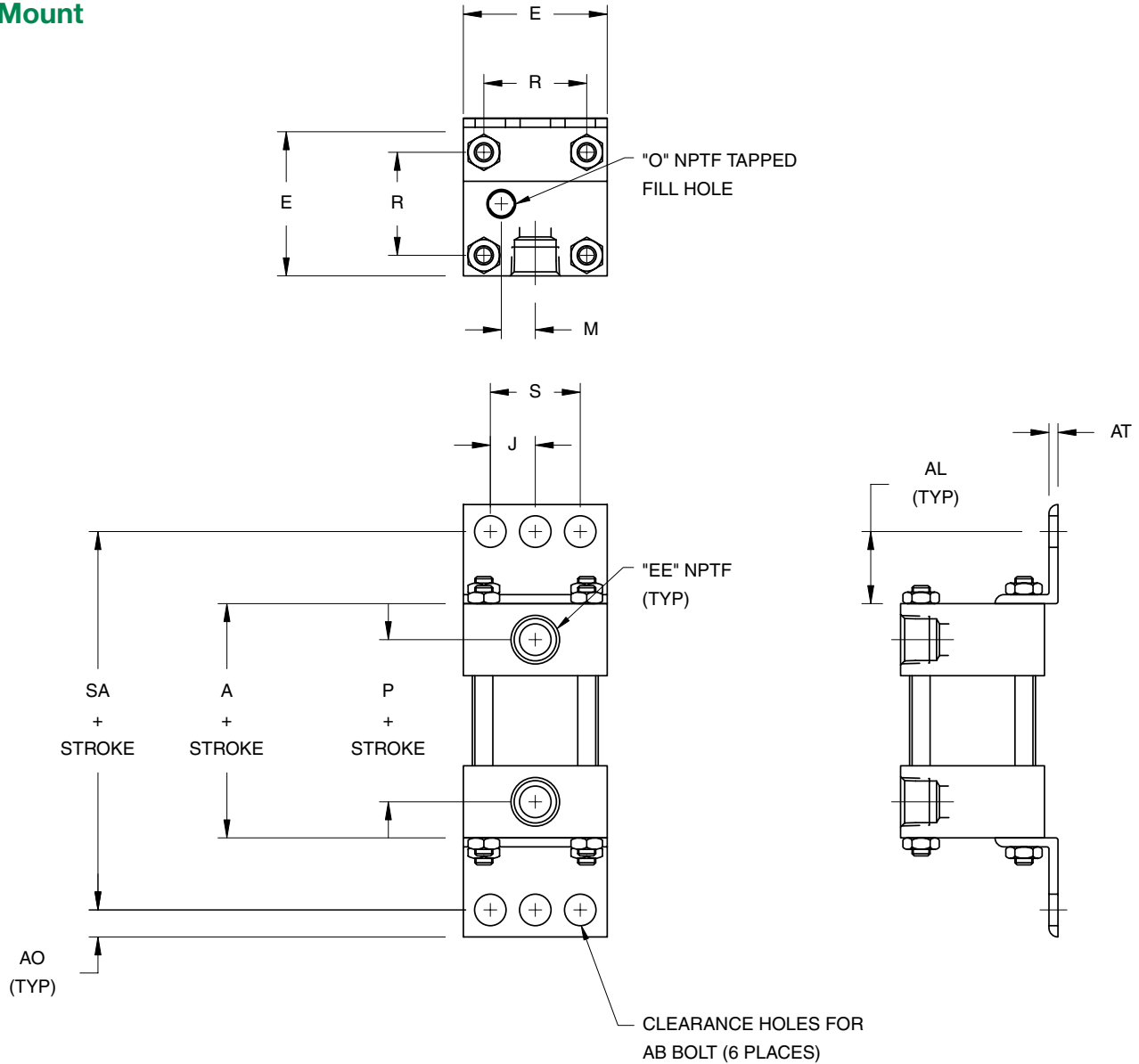

Bore	A	AO	AL	AT	J	E	EE	M	O	P	R	S	SA	AB
2"	2.00	0.38	1.00	0.13	0.88	2.50	3/8	0.56	1/4	1.12	1.84	1.75	4.00	3/8
2-1/2"	2.00	0.38	1.00	0.13	1.13	3.00	3/8	0.69	1/4	1.12	2.19	2.25	4.00	3/8
3-1/4"	2.50	0.50	1.25	0.13	1.38	3.75	1/2	0.88	3/8	1.38	2.76	2.75	5.00	1/2
4"	2.50	0.50	1.25	0.13	1.75	4.50	1/2	0.88	3/8	1.38	3.32	3.50	5.00	1/2
5"	2.50	0.63	1.38	0.19	2.13	5.50	1/2	1.31	3/8	1.38	4.10	4.25	5.25	5/8
6"	3.00	0.63	1.38	0.19	2.63	6.50	1/2	1.31	3/8	1.63	4.88	5.25	5.75	3/4
8"	3.00	0.69	1.81	0.25	3.56	8.50	3/4	2.25	1/2	1.63	6.44	7.13	6.63	3/4

Stop Tube Data

Step 1 - Determine which mount below corresponds to your application.

Step 2 - Determine the value of "L" from Table 1 below. Then find "L" dimension in Table 2 and read across to determine the required stop tube length.

Step 3 - Add the stop tube length to the original "L" value from Step 2. This is the corrected "L." If the corrected "L" still falls within the same range as the original "L" then this is the required stop length. Otherwise, use this number in Table 2 to determine the second stop tube length.

Step 4 - Add the second stop length to the original "L." If this value falls within the same range then the second stop tube length is the required length. Otherwise, repeat Step 4.

NOTE: Specify the effective stroke and the stop tube length when ordering.

Example:

Step 1: 10" bore cylinder, 1 3/4 diameter rod, P1 mount, 82 inch stroke
From catalog, XC = 10.375

From table 1, "L" = XC = (2 x Stroke)

Step 2: From Table 1, "L" = 10.375 + 164 = 174.375 inches
From Table 2, when "L" = 174.375, stop tube length = 14 inches

Step 3: Corrected "L" = 14 + 174.375 = 188.375 inches
From Table 2, when "L" = 188.375, stop tube length = 15 inches

Step 4: New corrected "L" = 15 + 174.375 = 189.375 inches
From Table 2, when "L" = 189.375, stop tube length = 15 inches

The stop tube length from Step 3 and 4 are the same, therefore, 15 inches is the required stop tube length.

Table 1

Mount Code	"L" (Inches)
S1*	4 x (WF + Stroke)
S2*	4 x (WF + Stroke)
S4*	4 x (WF + Stroke)
X3*	4 x (WF + Stroke)
X2*	4 x (WF + Stroke)
X1*	4 x (WF + Stroke)
T1	XG + Stroke
T2	XJ + (2 x Stroke)
T3	XI + Stroke

* "L" given is for an unsupported rod end. If rod end is supported with a guide less than 1" in width, divide "L" by 4. If rod end is supported with a guide greater than 1" in width, divide "L" by 8.

For P1 mount, "L" assumes that the rod extends and the cylinder pivots with the rod. Multiply "L" by four so the rod extends and the cylinder does not pivot with the rod.

Table 2

"L" (Inches)	Stop Tube Length (Inches)
0-40	0
41-50	1
51-60	2
61-70	3
71-80	4
81-90	5
91-100	6
101-110	7
111-120	8
121-130	9
131-140	10
141-150	11
151-160	12
161-170	13
171-180	14
181-190	15
191-200	16
201-210	17
211-220	18
221-230	19
231-240	20
241-250	21
251-260	22
261-270	23
271-280	24
281-290	25
291-300	26
301-310	27

Force Tables

The **extend force** is determined from Table 1 based on the operating pressure and cylinder bore size. Then determine the Retract Force by subtracting the "Retract Force Deduction" from the Extend Force. The "Retract Force Deduction" is found in Table 2 below corresponding to the piston rod diameter and operating pressure. These forces are theoretical based on areas with no friction allowance.

Table 1 Force Chart Extend

Bore	Piston Area	Pressure								Cubic Feet Displacement per Inch of Extended Stroke
		40	50	60	80	90	100	125	150	
1.50	1.77	71	88	106	141	159	177	221	265	.00102
2.00	3.14	126	157	188	251	283	314	393	471	.00182
2.50	4.91	196	245	295	393	442	491	614	736	.00284
3.25	8.30	332	415	498	664	747	830	1037	1244	.00480
4.00	12.57	503	628	754	1005	1131	1257	1571	1885	.00727
5.00	19.63	785	982	1178	1571	1767	1963	2454	2945	.01136
6.00	28.27	1131	1414	1696	2262	2545	2827	3534	4241	.01636

Table 2 Retract Force Deduction

Bore	Piston Area	Pressure								Cubic Feet Displacement per Inch of Extended Stroke
		40	50	60	80	90	100	125	150	
.625	.307	12	15	18	25	28	31	38	46	.00018
1.000	.785	31	39	47	63	71	79	98	118	.00045
1.375	1.485	59	74	89	119	134	148	186	223	.00086
1.750	2.405	96	120	144	192	216	241	301	361	.00139

Stop Tube Selection

Stop tubes are required for long stroke applications. The stop tube length is calculated based on the mount style, stroke and other mounting dimensions. Use the chart on page 25 to determine the stop tube length for all A Series cylinders 1 1/2" bore through 6" bore.

Common Cylinder Options

For spring extend/retract cylinders consult factory with bore, stroke and spring force requirements. FKM seals for ambient temperatures to 400 degrees Fahrenheit are also available. Bumpers are available upon request.

Approximate Cylinder Weights (lbs)

Bore	1-1/2"		2"		2-1/2"		3-1/4"		4"		5"		6"	
Piston Rod Diameter	5/8"	1"	5/8"	1"	5/8"	1"	1"	1-38"	1"	1-38"	1"	1-38"	1-38"	1-34"
X0, S4	2.10	2.80	2.70	3.40	3.60	4.30	7.10	8.40	9.30	10.80	13.00	14.00	22.00	22.50
F1, F2, S2	2.70	3.50	3.70	4.40	5.00	5.70	10.30	12.00	14.00	15.40	20.00	21.00	32.00	34.00
P2, P4	3.20	4.00	4.10	5.00	5.50	6.40	11.50	13.10	15.50	16.40	20.10	21.80	35.00	36.00
T1, T2	2.60	3.30	3.10	3.90	4.00	4.80	7.50	8.90	9.90	11.30	13.70	15.00	23.00	25.00
P1, P3, X1, X2, X3, S1	2.30	3.00	2.80	3.50	3.70	4.50	7.50	9.00	9.90	11.30	13.30	15.00	23.00	25.00
Per Inch Of Stroke	0.24	0.40	0.30	0.40	0.30	0.44	0.50	0.70	0.60	0.80	0.60	0.80	0.90	1.14

Metallic Rod Scraper

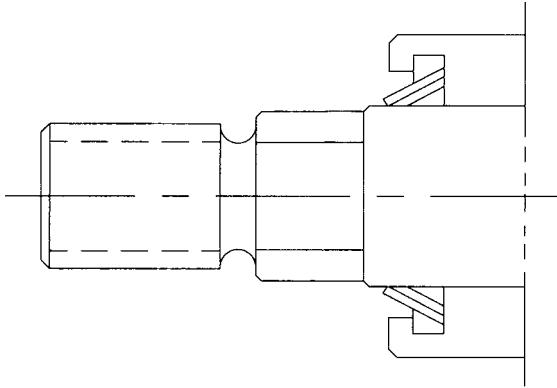

A rod scraper may be necessary when the cylinder must endure paint overspray, weld splatter or flyash.

Order as "MA" Option

Electroless Nickel Protection

Electroless Nickel Plated NFPA Air Cylinder for Use in Corrosive Environments

1. Tie rods and tie rod nuts are 300 series stainless steel.
2. Piston rod is 303 stainless steel turned, ground, polished and hard chrome plated.
3. Tube, head, cap, bushing retainer and all mounts are protected from corrosion with .0005 thick electroless nickel plating.
4. The rod bushing is a cutting edge PolyLube™ composite bushing.
5. Reed, Hall and Prox switches are NEMA 6 or IP67 approved for corrosive and wash down environments.
6. Mounting accessories are available with electroless nickel plating.

For detailed information regarding the properties of PolyLube™, call 1-800-918-9261.

Order as "NA" Option

Adjustable Stroke Cylinder

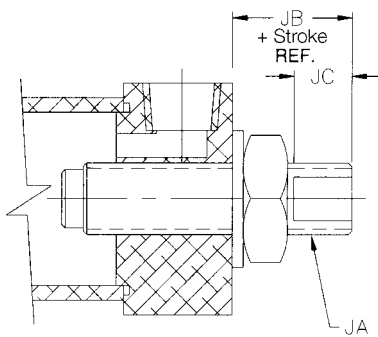

Order as "KA" Option

Bore	JA	JB	JC
1-1/2"	5/8-11	1.500	.500
2"	5/8-11	1.500	.500
2-1/2"	5/8-11	1.500	.500
3-1/4"	1-14	1.250	.500
4"	1-14	1.250	.500
5"	1-14	1.250	.500
6"	1-14	1.000	.500

Save Air Stroke Adjuster

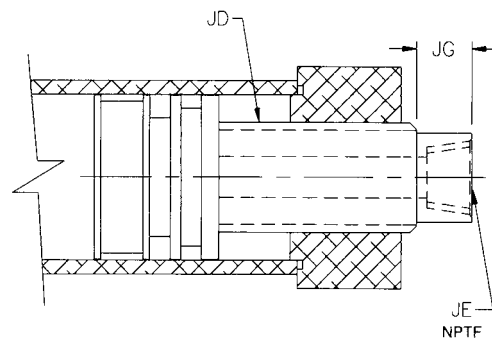

Order as "RA" Option

Bore	JD	JE	JG
1-1/2"	1-8 UNC-2A	3/8	0.50
2"	1-8 UNC-2A	3/8	0.50
2-1/2"	1 3/4-5 UNC-2A	1/2	0.50
3-1/4"	1 3/4-5 UNC-2A	3/4	0.75
4"	1 3/4-5 UNC-2A	3/4	0.75
5"	1 3/4-5 UNC-2A	3/4	0.75
6"	2-4 1/2 UNC-2A	1	0.75

Silencer Bumper Seal

Our “Silencer” design reduces the noise caused by the final impact of the piston against the cap. It also allows usage of standard pneumatic cushions in order to further reduce the amount of end of stroke noise and impact while still giving the deceleration benefits. When the cushion spear enters into the cushion seal, the cushioning effect takes place by trapping air and then metering it out at a rate set via the adjustable cushion needle.

Note: Silencer Bumper does not add length to the cylinder, but a minimum force of 100PSI must be applied to collapse the seals to reach the full extend and retract positions.

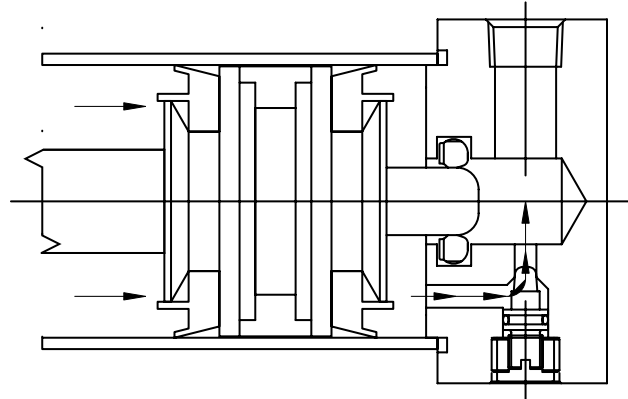

Technical Data

A Series Bore Sizes: 1 1/2", 2", 2 1/2", 4" and 5"
 Temperature: -20°F to 200°F
 Pressure Rating: 150 psi air

Static Stroke Length Reduction Based on PSI

Bore	0 PSI	20 PSI	40 PSI	60 PSI	80 PSI	100 PSI
1-1/2"	0.106	0.056	0.028	0.018	0.000	0.000
2"	0.090	0.070	0.046	0.037	0.018	0.000
2 1/2"	0.201	0.166	0.122	0.071	0.008	0.000
3 1/4"	0.160	0.102	0.082	0.048	0.038	0.000
4"	0.150	0.085	0.065	0.031	0.005	0.000
5"	0.219	0.158	0.099	0.530	0.015	0.000

Rod Boot

Our cylinder has a hardened bearing surface on the piston rod to protect it from external damage. Furthermore, the cylinder is also equipped with a highly efficient rod wiper. A rod wiper removes external contaminants such as dirt and dust. Exposed piston rods that are subjected to contaminants that contain hardening properties, i.e., paint, must be protected to ensure long life. In these applications, you should consider using a collapsing cover to protect the piston rod. The collapsing cover is commonly referred to as a Rod Boot.

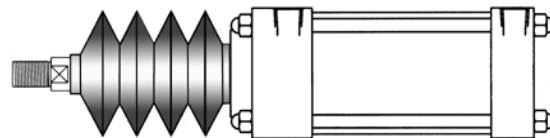

NOTE: High temperature rod boot available (option GA). Consult factory for detailed rod boot information.

Bore	0 PSI	20 PSI	40 PSI	60 PSI	80 PSI	100 PSI
1-1/2"	0.106	0.056	0.028	0.018	0.000	0.000
2"	0.090	0.070	0.046	0.037	0.018	0.000
2 1/2"	0.201	0.166	0.122	0.071	0.008	0.000
3 1/4"	0.160	0.102	0.082	0.048	0.038	0.000
4"	0.150	0.085	0.065	0.031	0.005	0.000
5"	0.219	0.158	0.099	0.530	0.015	0.000

Accessories

Accessories Guide

Rod Thread	Rod Clevis	Eye Bracket	Pivot Pin	Rod Eye	Clevis Bracket	Bore
7/16-20	A500-301	A500-101	A500-401	A500-201	A500-001	1 1/2, 2, 2 1/2
1/2-20	A500-302	A500-101	A500-401	A500-202	A500-001	1 1/2, 2, 2 1/2
3/4-16	A500-303	A500-102	A500-402	A500-203	A500-002	3 1/4, 4, 5
7/8-14	A500-304	A500-102	A500-403	-	-	-
1-14	A500-305	A500-103	A500-403	A500-204	A500-003	6
1 1/4-12	A500-306	A500-104	A500-404	A500-205	-	-
1 1/2-12	A500-307	A500-105	A500-405	A500-206	-	-

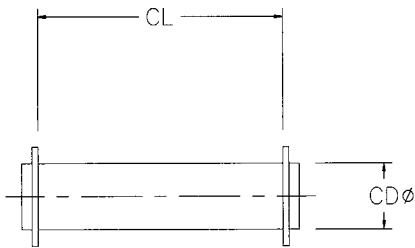

Pivot Pin

Part No.	CD	CL
A500-401	0.500	1.875
A500-402	0.750	2.625
A500-403	1.000	3.125
A500-404	1.375	4.125
A500-405	1.750	5.125

Included with mount codes P1, P2, P3 and P4

Rod Couplers

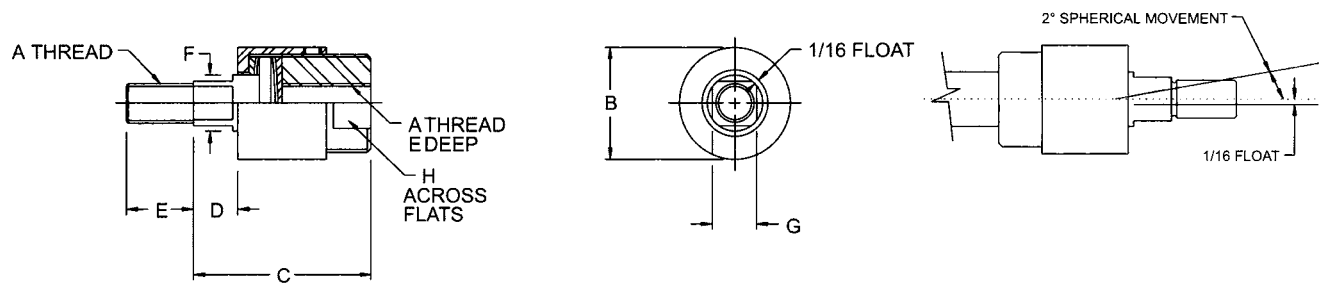

Standard Couplers

Part Number		A	B	C	D	E	F	G	H	Maximum Pull Load
Standard	Nickel									
A500-603	B500-603	7/16-20	1 1/4	2	1/2	3/4	5/8	9/16	1 1/8	2,535
A500-604	B500-604	1/2-20	1 1/4	2	1/2	3/4	5/8	9/16	1 1/8	3,500
A500-605	B500-605	5/8-18	1 1/4	2	1/2	3/4	5/8	1/2	1 1/8	4,750
A500-606	B500-606	3/4-16	1 3/4	2 5/16	5/16	1 1/8	31/32	7/8	1 1/2	8,750
A500-607	B500-607	7/8-14	1 3/4	2 5/16	5/16	1 1/8	31/32	7/8	1 1/2	9,750
A500-608	B500-608	1-14	2 1/2	2 15/16	1/2	1 5/8	1 3/8	1 1/4	2 1/4	16,125
A500-609	B500-609	1 1/4-12	2 1/2	2 15/16	1/2	1 5/8	1 3/8	1 1/4	2 1/4	19,600
A500-610	N35-1004	1 1/2-12	3 1/4	4 3/8	13/16	2 1/4	1 3/8	1 1/2	3	34,000

Dimensions: Inches

Accessories

Eye Bracket *

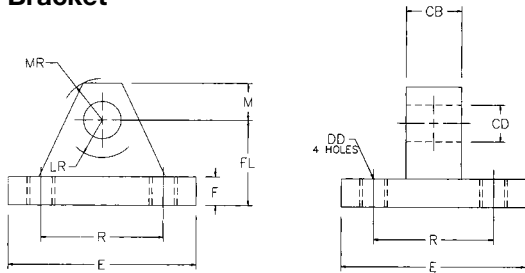

Rod Eye *

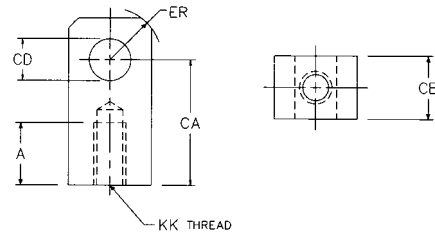

Clevis Bracket *

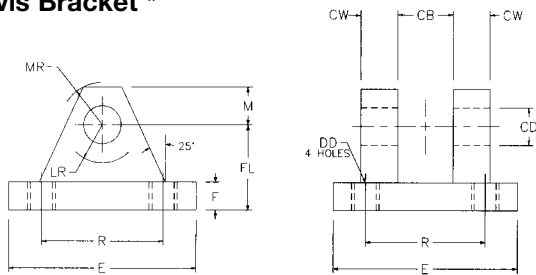

Rod Clevis *

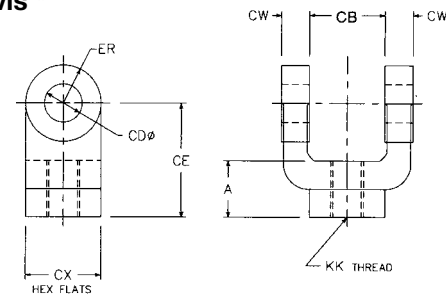

*Order pivot pin separately

Part No.	A	CA	CB	CD	CE	CW	CX	DD	E	ER	F	FL	KK	LR	M	MR	R
Clevis Bracket																	
A500-001	-	-	0.750	0.500	-	0.500	-	3/8-24	2.500	-	0.375	1.125	-	0.500	0.500	0.563	1.625
A500-002	-	-	1.250	0.750	-	0.625	-	1/2-20	3.500	-	0.625	1.875	-	1.063	0.750	1.063	2.563
A500-003	-	-	1.500	1.000	-	0.750	-	5/8-18	4.500	-	0.750	2.250	-	1.250	1.000	1.125	3.250
Eye Bracket																	
A500-101	-	-	0.750	0.500	-	-	-	0.406	2.500	-	0.375	1.125	-	0.750	0.500	0.563	1.630
A500-102	-	-	1.250	0.750	-	-	-	0.531	3.500	-	0.625	1.875	-	1.250	0.750	0.875	2.560
A500-103	-	-	1.500	1.000	-	-	-	0.656	4.500	-	0.750	2.250	-	1.500	1.000	1.250	3.250
A500-104	-	-	2.000	1.375	-	-	-	0.656	5.000	-	0.875	3.000	-	2.125	1.375	1.625	3.810
A500-105	-	-	2.500	1.750	-	-	-	0.906	6.500	-	0.875	3.125	-	2.250	1.750	2.125	4.950
Rod Clevis																	
A500-301	0.750	-	0.750	0.500	1.500	0.500	1.000	-	-	0.500	-	-	7/16-20	-	-	-	-
A500-302	0.750	-	0.750	0.500	1.500	0.500	1.000	-	-	0.500	-	-	1/2-20	-	-	-	-
A500-303	1.125	-	1.250	0.750	2.375	0.625	1.250	-	-	0.750	-	-	3/4-16	-	-	-	-
A500-304	1.625	-	1.500	1.000	3.125	0.750	1.500	-	-	1.000	-	-	7/8-14	-	-	-	-
A500-305	1.625	-	1.500	1.000	3.125	0.750	1.500	-	-	1.000	-	-	1-14	-	-	-	-
A500-306	2.000	-	2.000	1.375	4.125	1.000	2.000	-	-	1.375	-	-	1 1/4-12	-	-	-	-
A500-307	2.250	-	2.000	1.750	4.500	1.250	2.375	-	-	1.750	-	-	1 1/2-12	-	-	-	-
Rod Eye																	
A500-201	0.750	1.500	0.750	0.500	-	-	-	-	-	0.625	-	-	7/16-20	-	-	-	-
A500-202	0.750	1.500	0.750	0.500	-	-	-	-	-	0.625	-	-	1/2-20	-	-	-	-
A500-203	1.125	2.063	1.250	0.750	-	-	-	-	-	0.875	-	-	3/4-16	-	-	-	-
A500-204	1.625	2.813	1.500	1.000	-	-	-	-	-	1.188	-	-	1-14	-	-	-	-
A500-205	2.000	3.438	2.000	1.375	-	-	-	-	-	1.563	-	-	1 1/4-12	-	-	-	-
A500-206	2.250	4.000	2.500	1.750	-	-	-	-	-	2.000	-	-	1 1/2-12	-	-	-	-

A Series World application Detail

Round Tube and Tie Rod Detail

1. World Switch
2. Tie Rod Bracket
3. Adjustment Screw
4. Cylinder Tie Rod

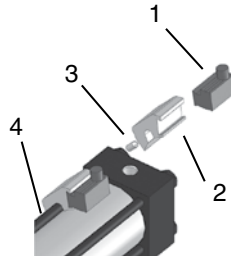

Profile Tube Detail

1. World Switch
2. Dove Tail extrusion

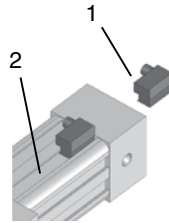

A series World Switch Bracket

Cylinders	Bore	Part Number
A series Tie Rod	1 1/2"	SB6-K01
A series Tie Rod	2"-2 1/2"	SB6-L01
A series Tie Rod	3 1/4"-4"	SB6-P01
A series Tie Rod	5"-6"	SB6-T01
A series Tie Rod	8"	SB6-W01
A series Profile	1 1/2"-3 1/4"	Direct Fit

A Series World Switch Hall Effect Part Numbers

P/N	Switch Style	Electrical Design	Output	Operating Voltage	Current Rating	Switching Power	Voltage Drop	NEMA IP Rating	Temperature Rating
SH6-031	Flying Lead	DC PNP	Normally Open	6-24 VDC	0.3 Amps Max.	7.2 Watts Max.	.5 Volts	NEMA 6	-25° to +75° C
SH6-032	Flying Lead	DC PNP	Normally Open	6-24 VDC	0.3 Amps Max.	7.2 Watts Max.	.5 Volts	NEMA 6	-25° to +75° C
SH6-021	M8 Connector	DC NPN	Normally Open	6-24 VDC	0.3 Amps Max.	7.2 Watts Max.	.5 Volts	NEMA 6	-25° to +75° C
SH6-022	M8 Connector	DC NPN	Normally Open	6-24 VDC	0.3 Amps Max.	7.2 Watts Max.	.5 Volts	NEMA 6	-25° to +75° C

Hall Effect Switch

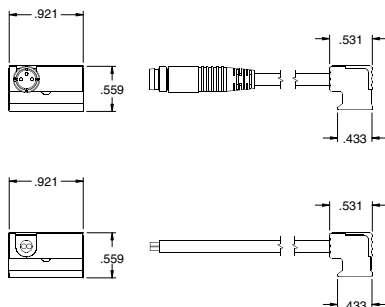

PNP Sourcing

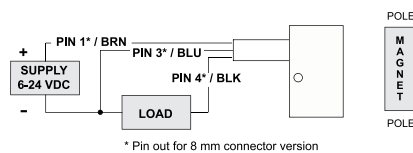

NPN Sinking

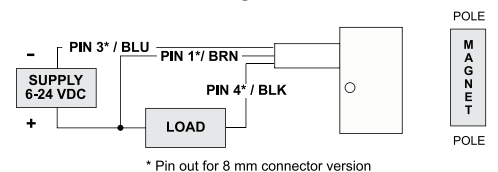

A Series World Switch Reed Switch Part Numbers

P/N	Switch Style	Electrical Design	Output	Operating Voltage	Current Rating	Switching Power	Voltage Drop	NEMA IP Rating	Temperature Rating
SR6-002	Flying Lead	AC/DC REED	Normally Open	5-120 VAC/DC	0.025 Amps Max. 0.001 Amps Min.	3 Watts Max.	3.5 Volts	NEMA 6	-25° to +75° C
SR6-004	Flying Lead	AC/DC REED	Normally Open	5-120 VAC/DC	0.5 Amps Max. 0.005 Amps Min.	10 Watts Max.	3.0 Volts	NEMA 6	-25° to +75° C
SR6-022	M8 Connector	AC/DC REED	Normally Open	5-50 VAC 5-60 VDC	0.025 Amps Max. 0.001 Amps Min.	3 Watts Max.	.5 Volts	NEMA 6	-25° to +75° C
SR6-024	M8 Connector	AC/DC REED	Normally Open	5-50 VAC 5-60 VDC	0.5 Amps Max. 0.005 Amps Min.	10 Watts Max.	3.0 Volts	NEMA 6	-25° to +75° C

Reed Switch - Normally Open Type SR6

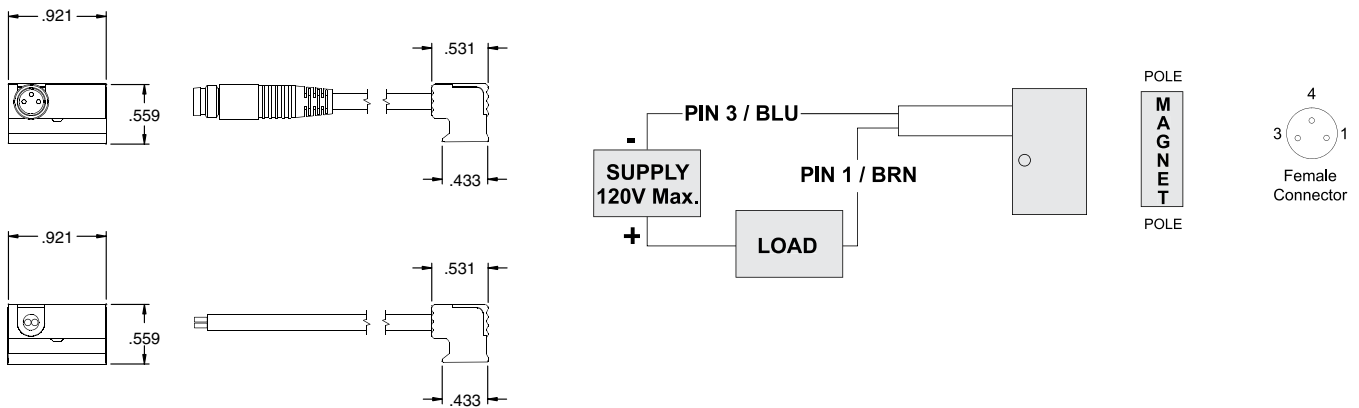

NFPA Interchangeable Cylinders

A Series (Tie Rod)

Bore	Bracket P/N
1 1/2"	N99-1181
2"	N99-1182
2 1/2"	N99-1182
3 1/4"	N99-1183
4"	N99-1183
5"	N99-1184
6"	N99-1184

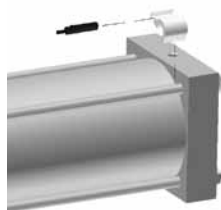

Sensor Description	Standard Cord Set	Quick Disconnect
Reed Switch	REED-FL2-00	REED-QDS-M8U
Hall PNP	PNP-FL2-00-U	PNP-QDS-M8-U
Hall NPN	NPN-FL2-00-U	NPN-QDS-M8-U

See page 32 for sensor specifications

A Series (Profile Tube)

Bore	Bracket P/N
1 1/2"	N99-1185
2"	N99-1185
2 1/2"	N99-1185

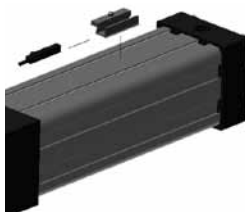

Sensor Description	Standard Cord Set	Quick Disconnect
Reed Switch	REED-FL2-00	REED-QDS-M8U
Hall PNP	PNP-FL2-00-U	PNP-QDS-M8-U
Hall NPN	NPN-FL2-00-U	NPN-QDS-M8-U

See page 32 for sensor specifications

How to Order - A Series Piston Rod Assembly

A92 - K 1 N 0 - 01 A - A A

Type

A92 = A Series Piston Rod Assembly

Bore

K = 1-1/2" R = 4"
L = 2" T = 5"
M = 2-1/2" U = 6"
P = 3-1/4" W = 8"

Rod Code

1 = Style # 1 Standard Rod Diameter
2 = Style # 2 Standard Rod Diameter
3 = Style # 3 Standard Rod Diameter
4 = Special Standard Rod Diameter
(must specify threads)
5 = Special Oversize Rod Diameter
(must specify threads)
6 = Style # 1 Oversize Rod Diameter
7 = Style # 2 Oversize Rod Diameter
8 = Style # 3 Oversize Rod Diameter
A = Style # 1 Second Oversize Rod Diameter
B = Style # 2 Second Oversize Rod Diameter
C = Style # 3 Second Oversize Rod Diameter
U = Male Coupling Rod End Standard Rod Diameter
V = Male Coupling Rod End Oversize Rod Diameter

Cushion

N = No Cushion
B = Both Ends Cushioned
H = Head End Cushioned
C = Cap End Cushioned

Magnet

0 = No Magnet
2 = Reed Magnet (Is Included with Piston Rod Assembly)

Options (Does Not Include Seals)

AA = No Option
BH = Bumpered Head End
CR = Cylindicator Ready "Stroke to Go"
DA = Double Rod
EB = Bumper Seals
FA = No Wrench Flats, No Turn Down
FB = Four Wrench Flats
GA = High Temperature Rod Boot
JN = Jam Nut
KA = Stroke Adjust
LB = Low Breakaway
NA = Nickel Plated
NN = Nylock Nut
NS = Cylindicator Ready "No Stroke to Go"
PP = PolyPak Piston
RA = Save Air Stroke Adjuster
RB = Rod Boot
SA = Stainless Rod
TI = "T" Seal Piston
VA = FKM Seals
1A* = Rod Extension
1B* = Rear Rod Extension
2A* = Thread Extension
2B* = Rear Thread Extension
3A = Rod Stud
3B = Rear Rod Stud
4A* = Stop Tube
4D* = Double Piston Stop Tube

* = must specify length
Consult factory for additional options.

Fractional Inches of Stroke

A = 0" E = 1/4" I = 1/2" M = 3/4"
B = 1/16" F = 5/16" J = 9/16" N = 13/16"
C = 1/8" G = 3/8" K = 5/8" O = 7/8"
D = 3/16" H = 7/16" L = 11/16" P = 15/16"

Full Inches of Stroke

00 = 0" Stroke
01 = 1" Stroke
02 = 2" Stroke
03 = 3" Stroke
04 = 4" Stroke
05 = 5" Stroke
99 = 99" Stroke

Note: Options listed are ones that apply to a piston rod assembly only.
Model number is set up to use option code supplied with original cylinder or with any above.
Note: Bumpers are not included with Piston Rod Assembly.

Sensing Part Numbers

PNP-FL2-00-U

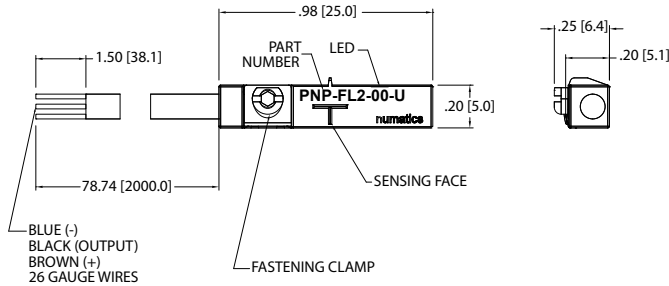

PNP-QDS-M8-U

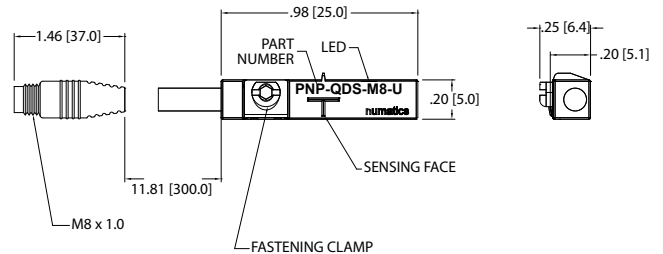





ELECTRICAL DESIGN	DC PNP
OUTPUT	Normally Open
OPERATING VOLTAGE	10-30 VDC
CURRENT RATING	100 mA
SHORT-CIRCUIT PROTECTION	Yes
OVERLOAD PROTECTION	Yes
REVERSE POLARITY PROTECTION	Yes
VOLTAGE DROP	< 2.5 V
CURRENT CONSUMPTION	< 12 mA
REPEATABILITY	< .2mm
POWER-ON DELAY TIME	< 30 ms
SWITCH FREQUENCY	> 3000 Hz
AMBIENT TEMPERATURE	-25°C to 85°C
PROTECTION	IP 67, III
HYSTERESIS	1.0mm
MAGNETIC SENSITIVITY	2.0 mT
TRAVEL SPEED	> 10 m/s
HOUSING MATERIAL	PA (Polyamide) Black; Fastening Clamp: Stainless Steel
FUNCTION DISPLAY SWITCHING STATUS	Yellow LED
CONNECTION	Flying Leads, Pur Cable (2m Long, 3 x26 Gauge Wire)
REMARKS	Clamping Screw with Combined Slot/Hexagon Socket Head AF 1.5 cULus - Class 2 Source Required
ACCESSORIES	Rubber Placeholder, Cable Clip, and Cut Sheet To Be Provided with Every Switch
AGENCY APPROVALS	CE cUL us RoHS

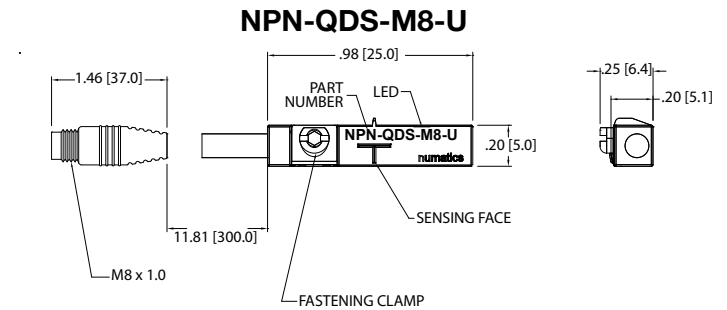
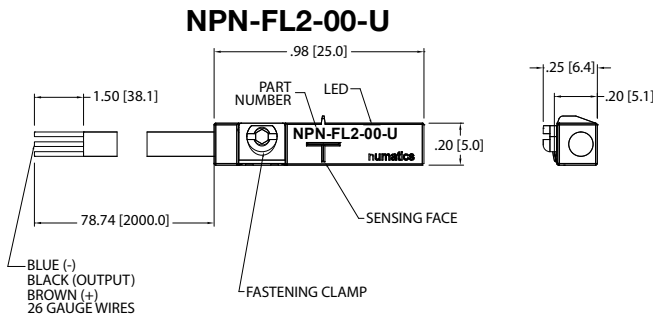

ELECTRICAL DESIGN	DC PNP
OUTPUT	Normally Open
OPERATING VOLTAGE	10-30 VDC
CURRENT RATING	100 mA
SHORT-CIRCUIT PROTECTION	Yes
OVERLOAD PROTECTION	Yes
REVERSE POLARITY PROTECTION	Yes
VOLTAGE DROP	< 2.5 V
CURRENT CONSUMPTION	< 12 mA
REPEATABILITY	< .2mm
POWER-ON DELAY TIME	< 30 ms
SWITCH FREQUENCY	> 3000 Hz
AMBIENT TEMPERATURE	-25°C to 85°C
PROTECTION	IP 67, III
HYSTERESIS	1.0mm
MAGNETIC SENSITIVITY	2.0 mT
TRAVEL SPEED	> 10 m/s
HOUSING MATERIAL	PA (Polyamide) Black; Fastening Clamp: Stainless Steel
FUNCTION DISPLAY SWITCHING STATUS	Yellow LED
CONNECTION	M8 Connector (Snap Fit) , Pur Cable (.3 m)
REMARKS	Clamping Screw with Combined Slot/Hexagon Socket Head AF 1.5 cULus - Class 2 Source Required
ACCESSORIES	Rubber Placeholder, Cable Clip, and Cut Sheet To Be Provided with Every Switch
AGENCY APPROVALS	CE cUL us RoHS

*Switches are not designed for wet environments. Please see your distributor for additional information.

Sensing Part Numbers



ELECTRICAL DESIGN	DC NPN
OUTPUT	Normally Open
OPERATING VOLTAGE	10-30 VDC
CURRENT RATING	100 mA
SHORT-CIRCUIT PROTECTION	Yes
OVERLOAD PROTECTION	Yes
REVERSE POLARITY PROTECTION	Yes
VOLTAGE DROP	< 2.5 V
CURRENT CONSUMPTION	< 12 mA
REPEATABILITY	< .2mm
POWER-ON DELAY TIME	< 30 ms
SWITCH FREQUENCY	> 3000 Hz
AMBIENT TEMPERATURE	-25°C to 85°C
PROTECTION	IP 67, III
HYSTERESIS	1.0mm
MAGNETIC SENSITIVITY	2.0 mT
TRAVEL SPEED	> 10 m/s
HOUSING MATERIAL	PA (Polyamide) Black; Fastening Clamp: Stainless Steel
FUNCTION DISPLAY SWITCHING STATUS	Yellow LED
CONNECTION	Flying Leads, Pur Cable (2m Long, 3 x26 Gauge Wire)
REMARKS	Clamping Screw with Combined Slot/Hexagon Socket Head AF 1.5 cULus - Class 2 Source Required
ACCESSORIES	Rubber Placeholder, Cable Clip, and Cut Sheet To Be Provided with Every Switch
AGENCY APPROVALS	  

ELECTRICAL DESIGN	DC NPN
OUTPUT	Normally Open
OPERATING VOLTAGE	10-30 VDC
CURRENT RATING	100 mA
SHORT-CIRCUIT PROTECTION	Yes
OVERLOAD PROTECTION	Yes
REVERSE POLARITY PROTECTION	Yes
VOLTAGE DROP	< 2.5 V
CURRENT CONSUMPTION	< 12 mA
REPEATABILITY	< .2mm
POWER-ON DELAY TIME	< 30 ms
SWITCH FREQUENCY	> 3000 Hz
AMBIENT TEMPERATURE	-25°C to 85°C
PROTECTION	IP 67, III
HYSTERESIS	1.0mm
MAGNETIC SENSITIVITY	2.0 mT
TRAVEL SPEED	> 10 m/s
HOUSING MATERIAL	PA (Polyamide) Black; Fastening Clamp: Stainless Steel
FUNCTION DISPLAY SWITCHING STATUS	Yellow LED
CONNECTION	M8 Connector (Snap Fit) , Pur Cable (.3 m)
REMARKS	Clamping Screw with Combined Slot/Hexagon Socket Head AF 1.5 cULus - Class 2 Source Required
ACCESSORIES	Rubber Placeholder, Cable Clip, and Cut Sheet To Be Provided with Every Switch
AGENCY APPROVALS	  

*Switches are not designed for wet environments. Please see your distributor for additional information.

Sensing Part Numbers

REED-FL2-00

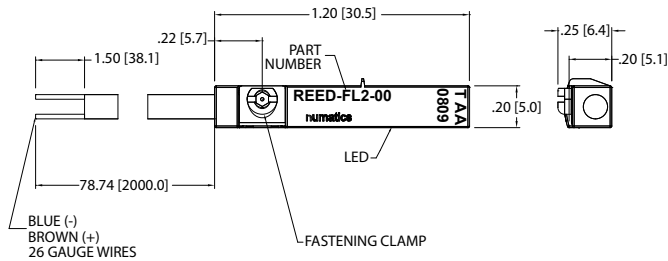

REED-QDS-M8U

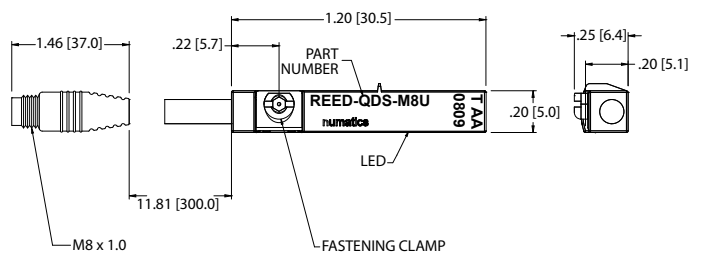

ELECTRICAL DESIGN	AC/DC REED
OUTPUT	Normally Open
OPERATING VOLTAGE	5-120 VAC/DC
CURRENT RATING	100 mA*
SHORT-CIRCUIT PROTECTION	No
OVERLOAD PROTECTION	No
REVERSE POLARITY PROTECTION	Yes
VOLTAGE DROP	< 5 V
REPEATABILITY	± .2mm
MAKETIME INCLUDING BOUNCE	< .6 ms
BREAKTIME	< .1 ms
SWITCHING POWER (MAX)	5 W
SWITCH FREQUENCY	1000 Hz
AMBIENT TEMPERATURE	-25°C to 70°C
PROTECTION	IP 67, II
HYSTERESIS	.9mm
HOUSING MATERIAL	PA (Polyamide) Black; Fastening Clamp: Stainless Steel
FUNCTION DISPLAY SWITCHING STATUS	Yellow LED
CONNECTION	Flying Leads, Pur Cable (2m Long, 2 x26 Gauge Wire)
REMARKS	*External Protective Circuit for Inductive Load (Valve, Contactor, Etc..) Necessary. Conforms to 2008 NEC Section 725 III, Class 2 Circuits Clamping Screw with Combined Slot/Hexagon Socket Head AF 1.5. No LED Function in case of Polarity in DC Operation
ACCESSORIES	Rubber Placeholder, Cable Clip, and Cut Sheet To Be Provided with Every Switch
AGENCY APPROVALS	CE RoHS

ELECTRICAL DESIGN	AC/DC REED
OUTPUT	Normally Open
OPERATING VOLTAGE	*5-60 VDC / 5-50 VAC
CURRENT RATING	100 mA
SHORT-CIRCUIT PROTECTION	No
OVERLOAD PROTECTION	No
REVERSE POLARITY PROTECTION	Yes
VOLTAGE DROP	< 5 V
REPEATABILITY	± .2mm
MAKETIME INCLUDING BOUNCE	< .6 ms
BREAKTIME	< .1 ms
SWITCHING POWER (MAX)	5 W
SWITCH FREQUENCY	1000 Hz
AMBIENT TEMPERATURE	-25°C to 70°C
PROTECTION	IP 67, II
HYSTERESIS	.9mm
HOUSING MATERIAL	PA (Polyamide) Black; Fastening Clamp: Stainless Steel
FUNCTION DISPLAY SWITCHING STATUS	Yellow LED
CONNECTION	M8 Connector (Snap Fit), Pur Cable (.3m)
REMARKS	*External Protective Circuit for Inductive Load (Valve, Contactor, Etc..) Necessary. Conforms to 2008 NEC Section 725 III, Class 2 Circuits M8 Connector voltage limited to 5-60 vdc / 5-50 vac to conform with 2008 IEC 61076-2-104 Clamping Screw with Combined Slot/Hexagon Socket Head AF 1.5. No LED Function in case of Polarity in DC Operation
ACCESSORIES	Rubber Placeholder, Cable Clip, and Cut Sheet To Be Provided with Every Switch
AGENCY APPROVALS	CE RoHS

*Switches are not designed for wet environments. Please see your distributor for additional information.

Quick Disconnect Cables

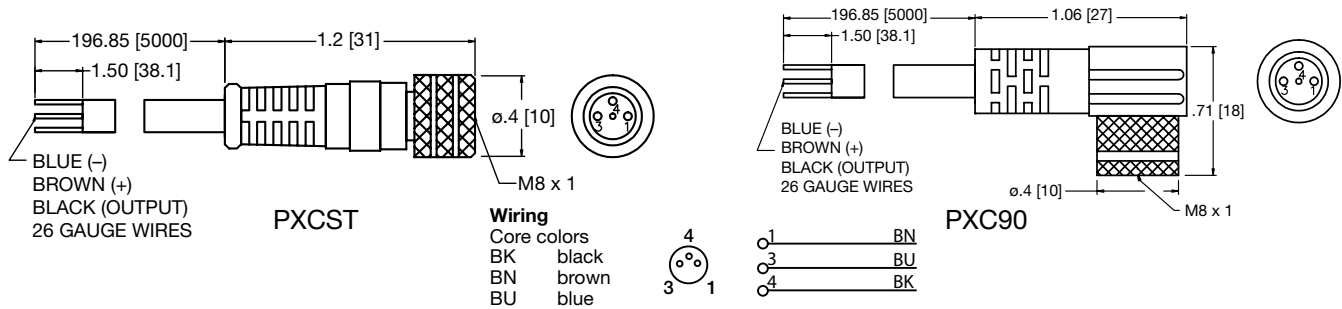

Order Code	Type	Operating Voltage	Current Rating	Cable Material	Protection	Connector
PXCST	Straight 5 m Cable (3 x 26 Gauge wire)	60 AC/75 DC	3 A	PUR	IP 68, III	M8
PXC90	90° 5 m Cable (3 x 26 Gauge wire)	60 AC/75 DC	3 A	PUR	IP 68, III	M8

How to Order - A Series Repair Kit

A98 - K 1 N - AA

Type

A98 = A Series Repair Kit

Bore

K = 1-1/2" R = 4"
L = 2" T = 5"
M = 2-1/2" U = 6"
P = 3-1/4" W = 8"

Rod Size

0 = Standard Rod
1 = Oversize Rod
2 = Second Oversize Rod

Options

AA = No Option
BK = Back to Back
BZ = Bronze Bushing
CR = Cylindicator Ready "Stroke to Go"
CZ = Composite Bushing
DA = Double Rod
EB = Silencer Bumpers
GA = High Temperature Rod Boot
LB = Low Breakaway
LT = Low Temp Seals
MA = Metallic Rod Scraper
MB = Rear Metallic Rod Scraper
NA = Nickel Plated
NS = Cylindicator Ready "No Stroke to Go"
PA = Polypak Rod Seal
PB = Rear Polypak Rod Seal
PP = Polypak Piston Seals
RA = Save Air Stroke Adjust
TI = "T" Seal Piston
VA = FKM Seals
4D = Double Piston Stop Tube

Cushion

N = No Cushion
B = Both Ends Cushioned
H = Head End Cushioned
C = Cap End Cushioned

Note: Options listed are ones that apply to a repair kit only.
Model number is set up to use option code supplied with original cylinder or with any above.

How to Order - A Series Seal Kit

A97 - K 1 N - AA

Type

A97 = A Series Seal Kit

Bore

K = 1-1/2" R = 4"
 L = 2" T = 5"
 M = 2-1/2" U = 6"
 P = 3-1/4" W = 8"

Rod Size

0 = Standard Rod
 1 = Oversize Rod
 2 = Second Oversize Rod

Options

AA = No Option
 BK = Back to Back
 CR = Cylindicator Ready "Stroke to Go"
 DA = Double Rod
 EB = Silencer Bumpers
 LB = Low Breakaway
 LT = Low Temp Seals
 MA = Metallic Rod Scraper
 MB = Rear Metallic Rod Scraper
 NS = Cylindicator Ready "No Stroke to Go"
 PA = Polypak Rod Seal
 PB = Rear Polypak Rod Seal
 PP = Polypak Piston Seals
 RA = Save Air Stroke Adjust
 TI = "T" Seal Piston
 VA = FKM Seals
 4D = Double Piston Stop Tube

Cushion

N = No Cushion
 B = Both End Cushioned
 H = Head End Cushioned
 C = Cap End Cushioned

Note: Options listed are ones that apply to a seal kit only.
 Model number is set up to use option code supplied with original cylinder or with any above.

Piston Rod Assembly Kit Installation Instructions

1. Loosen 4 Tie Rod Nuts (Part #20) to remove Piston/Rod Assembly (Part #18 & #19).
2. Carefully remove seals. (Part #12, #14, & #15). Any damage to the seals may result in leakage.
3. Lubricate piston seal(s) and wearband (Part #12) with supplied Numatics Lube. Examine seals before installing for any contamination. Contamination may cause leakage.
4. Install Piston Seal (Part #15). Make sure the piston seal is not twisted inside groove. Next install back-up rings if piston seal is a T-seal.
5. Install lubricated wearband onto piston. Sink piston/rod assembly into sinker tube.
6. Apply lube inside the cylinder tube (Part #17).
7. Sink piston/rod assembly into cylinder tube.
8. Press piston/rod assembly flush with the cylinder tube. Wipe off any lube from the face of the piston.
9. Examine all seals before reassembling cylinder for any contamination. Contamination may cause leakage.
10. Lightly grease Rod Seal (Part #3) of Loaded Bushing before installing. This will ease the installation of the rod bushing over the rod.
11. Reassemble cylinder. Loosely torque Tie Rod Nuts (Part #20) to allow head and cap to rotate slightly.
12. Before final torque, place cylinder on level surface. This will ensure that the cylinder head and cap are square. Torque Tie Rod Nuts (Part #20) in a crisscross pattern. Use torque tolerances chart for Tie Rod Nuts and Retainer Screws.
13. Stroke cylinder by hand. This will enable detection of any binding. If binding does occur, repeat steps 11-13.

See Seal Installation Guide on page 41 for additional (visual) instructions.

Repair Kit and Seal Kit Removal/Installation Instructions

1. Loosen 2 or 4 Retainer Screws (Part #11) to remove Loaded Bushing (Part # 9)
2. Loosen 4 Tie Rod Nuts (Part #20) to remove Piston/Rod Assembly (Part #18 & #19)
3. Carefully remove old seals. (Part [#1, #2, #3 Seal kit only], #5, #6, #7, #12, #14, & #15) Any damage to the seal grooves may result in leakage.
4. Lubricate new seals with supplied Numatics Lube. Examine seals before installing for any contamination. Contamination may cause leakage.
5. Install Piston Seal (Part #15). Make sure the piston seal is not twisted inside groove. Next install back-up rings (Part #14) if piston seal is a T-seal.
6. Install lubricated Wearband (Part #12) onto piston. Sink piston/rod assembly into sinker tube.
7. Apply lube inside the cylinder tube.
8. Sink piston/rod assembly into cylinder tube.
9. Press piston/rod assembly flush with the cylinder tube. Wipe off any lube from the face of the piston.
10. Place Tube End Seals (Part #6) into head and cap seal grooves. Examine seals after installing for any contamination. Contamination may cause leakage.
11. Install Rod Wiper (Part #1), Bushing O-ring (Part #2), and Rod Seal (Part #3) into bushing (Seal Kit only). Lightly grease Rod Seal and Bushing O-ring after installation. This will ease the installation of the rod bushing over the rod and into the head.
12. Reassemble cylinder except for loaded rod bushing (Part #9). First, loosely torque Tie Rod Nuts to allow head and cap to rotate slightly. Carefully place bushing over the rod until getting interference. With a twisting motion, slide the bushing down onto the rod and into the bushing pocket on the head.
13. Place Bushing Retainer (Part #10). Lightly tighten Retainer Screws (Part #11).
14. Before final torque, place cylinder on level surface to square head and cap. Torque Tie Rod Nuts in a crisscross pattern. Use the following charts for torque tolerances for Tie Rod Nuts and Retainer Screws.
15. Stroke cylinder by hand. This will enable detection of any binding. If binding does occur, repeat steps 12-14.

See Seal Installation Guide on page 41 for additional (visual) instructions.

Diagrams

Pneumatic Service Temperatures:
 Nitrile Seals: -10°F (-23°C) to 165°F (74°C)
 FKM Seals: 0°F (-17°C) to 400°F (204°C)

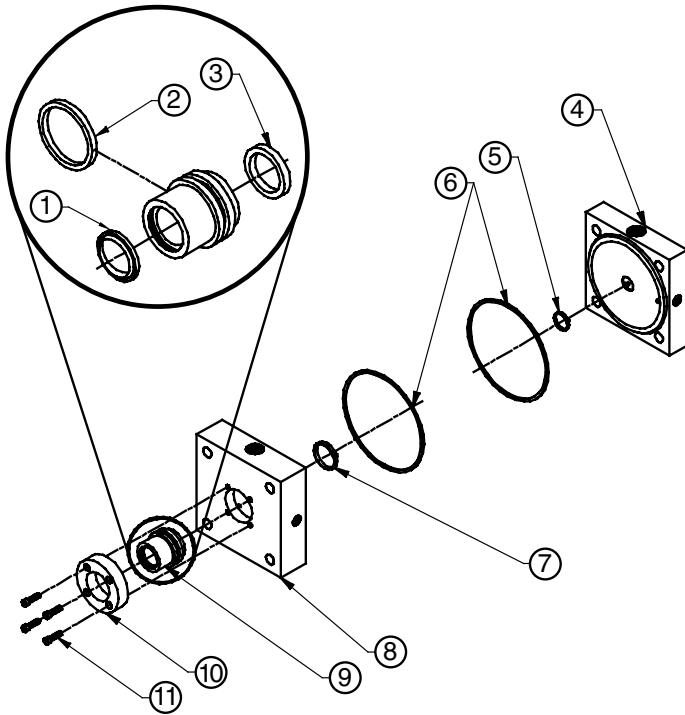

Head, Cap, and Bushing Assembly

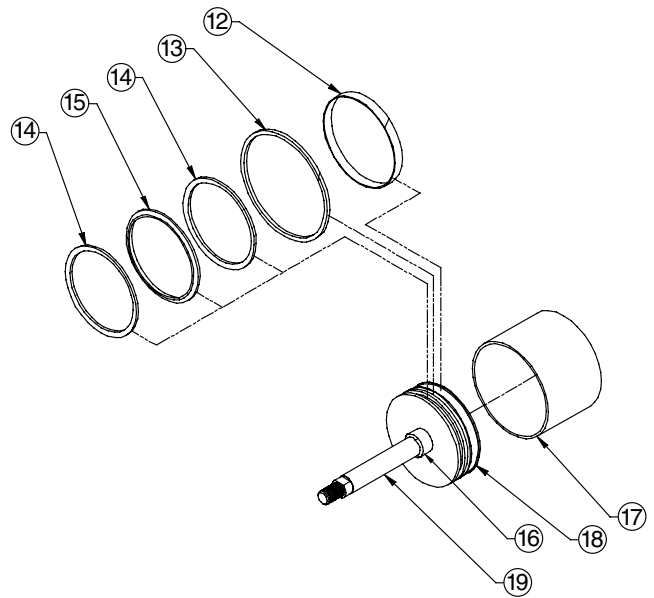

Piston/Rod Assembly

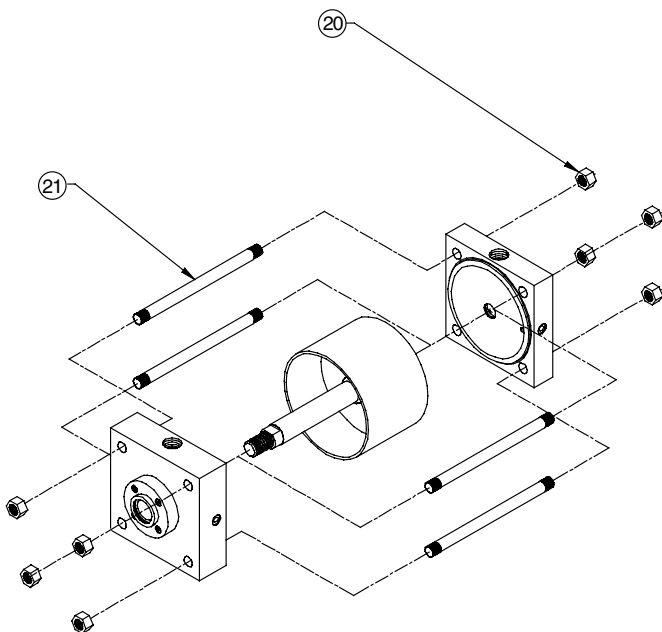

Cylinder Assembly and Tie Rod Torque

A Series

Part #	Description	Parts included in:		
		Seal Kit	Repair Kit	Piston/Rod Assembly
1	Rod Wiper	X		
2	Bushing O-ring	X		
3	Rod Seal	X		
4	Cap			
5	Cap Cushion Seal	X	X	
6	Tube End Seals	X	X	
7	Head Cushion Seal	X	X	
8	Head			
9	Loaded Bushing Assembly		X	
10	Bushing Retainer			
11	Retainer Screws			
12	Wearband	X	X	
13	Magnet			X
14	Back-up Rings	X	X	
15	Piston Seal	X	X	
16	Cushion Spear			X
17	Tube			
18	Piston			X
19	Rod			X
20	Hex Nuts			
21	Tie Rods			

Seal Installation Guide

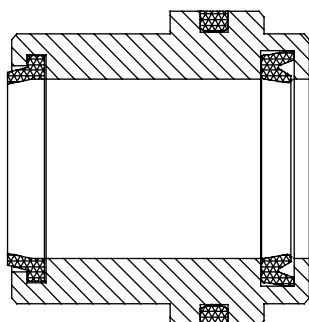

Loaded Bushing

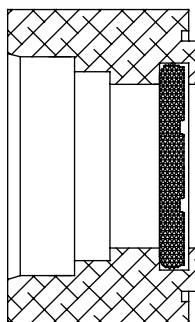

Cushioned Head or Cap

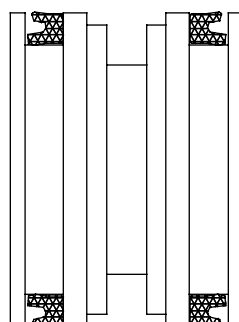

Low Breakaway Piston

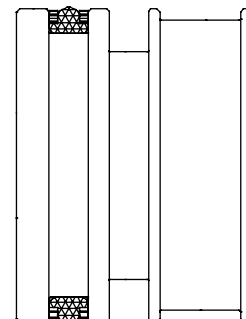

T-Seal Piston

Torque Tolerances (LBS-FT) Tie Rod Nut Part #20

Bore	Min.	Max.
1-1/2"	8	10
2"	15	20
2-1/2"	15	20
3-1/4"	23	30
4"	23	30
5"	50	60
6"	50	60
8"	80	90
10"	200	220
12"	200	220
14"	300	330

Retainer Screws Torque Tolerances (lbs-ft) Part #11

Size	Min.	Max.
#10-32	1	1.5
1/4-28	5	7
5/16-24	10	12

Note: Sinker Tubes are not included in kits. They can be ordered using the part numbers from the provided chart.

Sinker Tube Part Numbers

Bore	Part #
1-1/2"	A06-K91
2"	A06-L91
2-1/2"	A06-M91
3-1/4"	A06-P91
4"	A06-R91
5"	A06-T91
6"	A06-U91
8"	A06-W91
10"	A06-X91
12"	A06-Y91
14"	A06-B91



World Class Supplier of Pneumatic Components



World Headquarters

USA Numatics, Incorporated

46280 Dylan Drive
Novi, Michigan 48377

P: 248-596-3200
F: 248-596-3201

Canada Numatics, Ltd

P: 519-758-2700
F: 519-758-5540

México - Ascomatica SA de CV

P: 52 55 58 09 56 40 (DF y Area metropolitana)
P: 01 800 000 ASCO (2726) (Interior de la República)
F: 52 55 58 09 56 60

Brazil Ascoval Ind.e Comercio Ltda

P: (55) 11-4208-1700
F: (55) 11-4195-3970